

# THYRITOP SERIE 600

40 to 600 A  
power controllers



# TABLE OF CONTENTS

<b>Table of Contents .....</b>	<b>1</b>	
<b>Preface .....</b>	<b>3</b>	
Device data and initial checks.....	3	
Warnings and safety.....	3	
Disposal.....	3	
Typographical conventions used in the manual .....	4	
Liability disclaimer .....	4	
Copyright.....	4	
<b>1. General Description .....</b>	<b>5</b>	
1.1. Summary.....	5	
1.1.1. Profile.....	5	
1.1.2. Control functions.....	5	
1.1.3. Diagnostics, preventive maintenance and alarms .....	5	
1.1.4. Configuration .....	6	
1.1.5. Fieldbus .....	6	
1.1.6. More.....	6	
1.2. Field of use.....	6	
1.3. Technicians and operators .....	6	
1.4. Thyritop 600 .....	7	
1.4.1. Main elements of the Thyritop 600, 40 A ... 300 A.....	7	
1.4.2. Main elements of the Thyritop 600, 400 A ... 600 A models .....	8	
1.5. Rotary switches.....	8	
1.6. Configuration dip switches .....	9	
1.6.1. Type of load connection.....	9	
1.6.2. Initialisation procedure and loading of default values..	9	
1.7. LED indicator functions.....	10	
1.8. Dimensions.....	11	
1.8.1. Dimensions of Thyritop 600, 40 A ... 300 A models...11		
1.8.2. Dimensions of Thyritop 600, 400 A ... 600 A .....	12	
<b>2. Installation and power supply .....</b>	<b>14</b>	
2.1. Installing the controller .....	14	
2.1.1. General installation rules.....	14	
2.1.2. Positioning and minimum ventilation space .....	14	
2.1.3. Fixing to the electrical panel .....	14	
2.2. Power supply .....	16	
2.3. EMC and LVD conformity.....	16	
2.3.1. EMC conformity .....	16	
2.3.2. EMC filters.....	16	
2.3.3. LVD or low voltage conformity .....	16	
2.3.4. Electrical safety .....	16	
2.5. Thyritop 600 insulation diagram.....	18	
<b>3. Electrical connections .....</b>	<b>19</b>	
3.1. Description of the connections .....	19	
3.2. Inputs .....	21	
3.2.1. J3 connector - Power supply and digital inputs. ....	21	
3.2.2. J4 Connector - Analogue control inputs.....	22	
3.2.3. J5 connector - External CT inputs (optional) .....	23	
3.3. Outputs .....	24	
3.3.1. J1 connector - outputs 5...8 (optional).....	24	
3.3.1.1. <i>Optional D-type outputs (digital)</i> .....	24	
3.3.1.2. <i>Optional outputs type W (analogue)</i> .....	25	
3.3.1.3. <i>Optional outputs type R (relays)</i> .....	25	
3.3.2. J2 connector - outputs 9 and 10 (relay type).....	25	
3.4. Serial communication port .....	26	
3.4.1. Location of the ports.....	26	
3.4.2. PORT1 (local bus): Modbus serial interface - connectors J8 and J9 .....	27	
3.4.3. PORT2 (optional Fieldbus) type M: Modbus RTU / Modbus RTU - connectors S4, S5.....	27	
3.4.4. PORT2 (optional Fieldbus) type P: Modbus RTU / Profibus DP - connectors S4, S5.....	28	
3.4.5. PORT2 (optional Fieldbus) type C: Modbus RTU / CANopen - connectors S4, S5 .....	29	
3.4.6. PORT2 (optional Fieldbus) type E: Modbus RTU / Ethernet Modbus TCP - connectors S4, S5 .....	30	
3.4.7. PORT2 (optional Fieldbus) type E6 / E7 / E8 - connectors S4, S5 .....	31	
3.5. Power connections .....	32	
3.5.1. Recommended cable cross-section with Thyritop 600 40 A ... 300 A .....	32	
3.5.2. Recommended cable cross-section with Thyritop 600 400 A ... 600 A .....	33	
3.6. Connection examples - Power section for Thyritop 600 40 A...Thyritop 600 300 A .....	35	
3.6.1. Connection example for single-phase Thyritop 600 (1PH) for a single-phase load.....	35	
3.6.2. Connection example for single-phase Thyritop 600 (1PH) for a single-phase load with transformer .....	36	
3.6.3. Connection example for single-phase Thyritop 600 (1PH) control option 4 for single-phase load with transformer .....	37	
3.6.4. Connection example for two-phase Thyritop 600 (2PH) for 2 independent single-phase loads .....	38	
3.6.5. Connection example for two-phase Thyritop 600 (2PH) for a three-phase star load without neutral.....	39	
3.6.6. Connection example for two-phase Thyritop 600 (2PH) for a three-phase star load without neutral with trans- former.....	40	
3.6.7. Connection example for two-phase Thyritop 600 (2PH) control option 4 for a three-phase star load without neutral with transformer.....	41	
3.6.8. Connection example for two-phase Thyritop 600 (2PH) for a three-phase closed delta load .....	42	
3.6.9. Connection example for two-phase Thyritop 600 (2PH) for a three-phase closed delta load with transformer	43	
3.6.10. Connection example for two-phase Thyritop 600 (2PH) control option 4 for a closed delta load with transformer.....	44	
3.6.11. Connection example for three-phase Thyritop 600 (3PH) for 3 independent single-phase loads.....	45	
3.6.12. Connection example for three-phase Thyritop 600 (3PH) for a three-phase star load with neutral .....	46	
3.6.13. Connection example for three-phase Thyritop 600 (3PH) for a three-phase star load without neutral.....	47	
3.6.14. Connection example for three-phase Thyritop 600 (3PH) for a three-phase star load without neutral with transformer.....	48	
3.6.15. Connection example for three-phase Thyritop 600 (3PH) control option 4 for a three-phase star load without neutral with transformer .....	49	
3.6.16. Connection example for three-phase Thyritop 600 (3PH) for three-phase closed delta load .....	50	
3.6.17. Connection example for three-phase Thyritop 600 (3PH) for a three-phase closed delta load with trans- former.....	51	
3.6.18. Connection example for three-phase Thyritop 600 (3PH) control option 4 for three-phase closed delta load with transformer.....	52	
3.6.19. Connection example for three-phase Thyritop 600 (3PH) for three-phase open delta load.....	53	
3.6.20. Connection example for three-phase Thyritop 600 (3PH) for 3 independent loads in open delta .....	54	
3.7. Connection examples - Power section for Thyritop 600 400 A ...600 A .....	55	
3.7.1. Connection example for single-phase Thyritop 600 (1PH) for a single-phase load.....	55	
3.7.2. Connection example for single-phase Thyritop 600 (1PH) for a single-phase load with transformer .....	56	
3.7.3. Connection example for two-phase Thyritop 600 (2PH) for 2 independent single-phase loads .....	57	

3.7.4.	Connection example for two-phase Thyritop 600 (2PH) for a three-phase star load without neutral.....	58
3.7.5.	Connection example for two-phase Thyritop 600 (2PH) for a three-phase star load without neutral with transformer.....	59
3.7.6.	Connection example for two-phase Thyritop 600 (2PH) for a three-phase closed delta load.....	61
3.7.7.	Connection example for two-phase Thyritop 600 (2PH) for a three-phase closed delta load with transformer.....	62
3.7.8.	Connection example for three-phase Thyritop 600 (3PH) for 3 independent single-phase loads.....	64
3.7.9.	Connection example for three-phase Thyritop 600 (3PH) for a three-phase star load with neutral.....	65
3.7.10.	Connection example for three-phase Thyritop 600 (3PH) for a three-phase star load without neutral.....	66
3.7.11.	Connection example for three-phase Thyritop 600 (3PH) for a three-phase star load without neutral with transformer.....	67
3.7.12.	Connection example for three-phase Thyritop 600 (3PH) for three-phase closed delta load.....	69
3.7.13.	Connection example for three-phase Thyritop 600 (3PH) for a three-phase closed delta load with transformer.....	70
3.7.14.	Connection example for three-phase Thyritop 600 (3PH) for three-phase open delta load.....	72
3.7.15.	Connection example for three-phase Thyritop 600 (3PH) for 3 independent loads in open delta.....	73
3.8.	Notes on use with inductive loads and transformers.....	74
<b>4.</b>	<b>Operating modes.....</b>	<b>75</b>
4.1.	Trigger modes.....	75
4.1.1.	“Zero crossing” mode.....	75
4.1.1.1.	<i>ZC - constant cycle time</i> .....	75
4.1.1.2.	<i>BF - variable cycle time</i> .....	75
4.1.1.3.	<i>HSC - Half single cycle</i> .....	76
4.1.2.	Phase angle (PA).....	76
4.2.	Additional functions.....	77
4.2.1.	Softstart.....	77
4.2.2.	RMS current limit.....	77
4.2.3.	DT - Delay triggering.....	78
4.3.	Digital input (PWM).....	79
<b>5.</b>	<b>Using Port 1 “Modbus RTU”.....</b>	<b>80</b>
5.3.1.	“AutoBaud Port 1” procedure.....	80
<b>6.</b>	<b>Maintenance.....</b>	<b>81</b>
6.1.	Periodic cleaning.....	81
6.1.1.	Overtemperature alarm.....	81
6.2.	Replacing the internal fuse.....	82
6.3.	Replacing the fieldbus interface board.....	84
6.4.	Disposal.....	84
<b>7.</b>	<b>Technical specifications.....</b>	<b>85</b>
7.1.	Derating curves.....	92
<b>8.</b>	<b>Order codes.....</b>	<b>93</b>
<b>9.</b>	<b>Accessories.....</b>	<b>94</b>
9.1.	Kit, keypad and cables.....	95
9.2.	Ultrarapid fuses.....	95
9.3.	Short-circuit protection / SCCR.....	96

# PREFACE

## Device data and initial checks

Write down the order code and other plate data displayed on the label on the outside of the controller (see illustration) here. Should you require technical assistance, this information must be given to Pyrocontrole Customer Service. Check also that the product is intact and has not been damaged during transport, and that the packaging contains the Instructions for Use and Warnings in addition to the product.

Any inconsistencies, missing items or obvious signs of damage must be reported immediately to your Pyrocontrole dealer.

Check that the order code corresponds to the configuration required for the intended use of the controller, by consulting chapter “8. Order codes”.

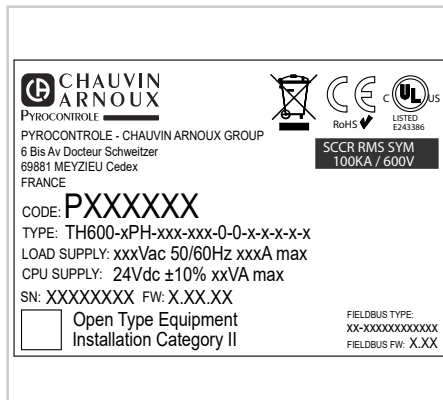

Serial number	<b>SN</b>	
Finished product code	<b>CODE</b>	
Order code	<b>TYPE</b>	
Rated voltage and rated current	<b>SUPPLY</b>	
Firmware version	<b>VERS.</b>	

## Warnings and safety

This document supplements the following manuals:

- Thyritop 600 Configuration and Programming Manual, “Thyritop 600 (last update).pdf.

Always make sure you have the latest version of the manual, which can be downloaded freely from the Pyrocontrole website ([www.pyrocontrole.com](http://www.pyrocontrole.com)).

The devices described in the manual must be installed by qualified technicians, following current laws and regulations and in accordance with the instructions given in this manual.

Installation and/or maintenance technicians must read this manual and carefully follow the instructions given here and in the annexes as Pyrocontrole cannot be held liable for damage to persons, property and/or the product through failure to comply with the following conditions. This manual must be available to the people who interact with the devices described here.

Before interacting with the Thyritop 600 power controller, the operator must be sufficiently trained in the operation, emergency, diagnostics and maintenance procedures for the devices.

If the Thyritop 600 power controllers are used in applications with risk of damage to persons, machines or materials, they must be combined with auxiliary alarm devices. It is advisable to provide the possibility of checking alarm activation also during normal operation.

Do not touch the terminals on the device when it is powered.

In the event of suspected instrument malfunctions, before contacting the Pyrocontrole Technical Service, it is advisable to read the Troubleshooting Guide in the “Maintenance” section and the F.A.Q. (Frequently Asked Questions) section on the Pyrocontrole website [www.pyrocontrole.com](http://www.pyrocontrole.com).

## Disposal



The instrument must be segregated from other waste at the end of its useful life.

The user must take the equipment at the end of its useful life to an appropriate sorting centre for electrotechnical and electronic waste, or a similar facility, in accordance with the regulations in force in the country of installation, in order to dispose of the components which are potentially harmful to the environment.

This helps prevent negative effects on the environment and health and facilitates recycling of the materials from which the instrument is made.



---

## Typographical conventions used in the manual

---

Pay attention when the following symbols are found in the manual.



This indicates particularly important information relevant to correct product operation or safety, or provide instructions that must be strictly followed.



This indicates a suggestion that could be helpful for better use of the device.



This indicates a risk condition for the installation technician or user due to hazardous voltages.



This indicates a reference to other technical documents that may be downloaded from [www.pyrocontrole.com](http://www.pyrocontrole.com).



This calls the reader's attention to a specific point.

---

## Liability disclaimer

---

Although all information contained within this document has been carefully checked, Pyrocontrole cannot be held liable for the possible presence of errors, or for damage to persons or property due to improper use of this manual.

Pyrocontrole also reserves the right to make changes to the content and form of this document and to the features of the devices it describes at any time without prior notice.

The technical and performance data given in this manual are to be considered as a guide for the user to determine the suitability for a certain use and are not a guarantee. They may be the result of Pyrocontrole test conditions and the user must compare them to his/her real application requirements.

Pyrocontrole cannot be held in any way liable for damage to persons or property resulting from tampering or use that is incorrect, improper or otherwise incompliant with the features of the controller and the instructions contained in this manual.

Pyrocontrole shall not be liable for installations upstream or downstream from the instrument.

---

## Copyright

---

This document and its annexes may be freely reproduced, provided that the contents are not modified in any way and each copy includes this warning and the statement of Pyrocontrole ownership.

Pyrocontrole and Pyrotools are trademarks of Pyrocontrole.

The document may mention or reproduce trademarks and logos of third parties. Pyrocontrole acknowledges the rights over these trademarks or logos of their respective owners.

# 1. GENERAL DESCRIPTION

## 1.1. Summary

### 1.1.1. Profile

The Advanced Power Controllers of the Thyritop 600 series are self-contained units with the capability of controlling high electrical power levels for various types of single-phase, two-phase and three-phase heating elements. The controllers allow great flexibility of use in all current and voltage ratings, from 40 A to 600 A and at nominal voltages of 480 Vac, 600 Vac and 690 Vac.

They are ideal for accurate, stable temperature control in industrial heating systems.

Their advanced load control functions allow the management of linear resistors with a low thermal coefficient, non-linear resistors with a high thermal coefficient, infrared lamps, and single-phase and three-phase symmetrical and asymmetrical transformers.

Compact mechanics, together with ease of wiring with front connections and plug-in connectors and easy configuration methods ensure considerable savings in terms of panel space and installation time, without sacrificing robustness and a notable diagnostic capacity.

### 1.1.2. Control functions

All Thyritop 600 models can be operated in different modes to adapt to the various control solutions and architectures found in the field.

The three analogue inputs are highly configurable, so that both two-phase and three-phase devices can be controlled with a single command, and each available module can be controlled individually and independently.

Thyritop 600s can also be operated with digital ON/OFF controls or in PWM mode, through potentiometers, using one of the various Fieldbuses that complete the options of this range.

Flexibility in the control of electrical loads, even very different from each other, is guaranteed by a vast choice of trigger types, freely configurable on all models.

There is a choice of “**Zero Crossing**” (ZC) mode with fixed cycle times or “**Burst Firing**” (BF) mode with optimised cycle times, for linear loads and systems with high thermal inertia.

There is also the option of faster firing modes, such as “**Half Single Cycle**” (HSC), which is ideal for handling mid-wave IR lamps, and of “**phase angle**” (PA) control, for SWIR lamps, non-linear heating elements such as silicon carbide, silicon molybdenum and both single and three-phase transformer primaries.

Whichever control configuration is chosen, Thyritop 600 models are able to deliver the desired electrical power, from 0% to 100%, with precision.

The following functions complete the control:

- softstart at power-on,
- current limits settable on both peak values and RMS values,
- closed-loop feedback algorithms for voltage, current and power, which guarantee supply stability even in the presence of variations and disturbances in rated

values.

Some functions of the Thyritop 600 range are designed for specific applications and problems:

- For **systems with three-phase transformers**, any breakages of three-phase load branches are managed by the controller, which provides an immediate alarm signal while continuing to supply energy to the two intact phases, allowing the process to remain in a holding condition.
- In **heat treatments with non-linear resistors**, such as silicon carbide, heating elements can be brought up to temperature with “phase angle” control and active current limits, with automatic switching to “zero crossing” control when the elements are at temperature and there are no more current peaks, returning to “phase angle” control automatically only if further peaks reoccur.
- Three-phase transformers are very often used in **industrial furnaces**, with symmetrical or asymmetrical primary/secondary connections. Thyritop 600 controllers can manage both types indiscriminately without any impact on performance.
- Auxiliary voltage (V load) and current (external CT) inputs allow proper management of all applications where cable length and transformer type require **precise voltage and current measurement exactly on the load**, regardless of other plant engineering factors.
- In the case of several loads managed by different controllers, there is a need to **rationalise and synchronise the power outputs of the individual controllers** so as to reduce peaks of current/energy supplied instantly or, in some cases, limit the total value to a settable maximum. These functions are performed by a special external controller, the Pyro-ALM, capable of managing up to 64 controllers and configurable via VNC.

### 1.1.3. Diagnostics, preventive maintenance and alarms

Great care has been taken in the development of diagnostic, preventive maintenance and alarm functions that can be associated with current, voltage and power values and operating temperatures. The process and power controller are continuously monitored.

#### For current values:

- Total or partial interrupted load alarm with alarm threshold teach-in.
- SCR short circuit alarm.
- Short circuit or surge load alarm.
- Internal fuse breakage alarm.

#### For voltage values:

- No line voltage alarm.
- Unbalanced three-phase line alarm.
- Indication of incorrect phase rotation in three-phase systems (without interruption of controller operation)

---

**For temperature values:**

- Exclusive continuous temperature measurement of all power terminals with an alarm for loose terminal diagnosis.
- Continuous monitoring of the internal temperature of the power module with automatic disconnection and an alarm signal in the event of over-temperature.
- Fan output temperature measurement for electrical panel cooling system efficiency diagnostics.
- Insufficient fan power alarm.

The Pyrotools configuration software also offers an extensive list of additional diagnostic conditions, such as alarm status storage, for immediate and easy analysis in the event of a fault.

### 1.1.4. Configuration

The Thyritop 600 controllers have been designed with various configuration levels to make initial start-up operations as simple and intuitive as possible.

The Pyrotools configuration software (freely downloadable from the Pyrocontrole site [www.pyrocontrole.com](http://www.pyrocontrole.com)) has a “Smart Configuration” procedure to configure the controller through a few targeted questions, with limited need for knowledge of the parameters and their meanings. At the end of the procedure (average duration 5 minutes) the controller is ready to pilot the load.

Another section of the software contains the “Wizard” pages, showing the main parameters divided into topics, with a part of the parameter monitoring always active.

With Pyrotools, you can create and save entire parameter recipes and easily duplicate them on other devices. Parameters can also be monitored and displayed graphically with the oscilloscope function.

## 1.2. Field of use

---

As the Advanced Power Controller can be used in a multitude of installations and environments, adequate technical training is required to make full use of the instrument’s potential.

In any event, the instrument must always be used within the limits indicated in the technical specifications in the accompanying documentation.

Regardless of any other consideration, **it is always strictly forbidden to:**

- use the instrument or parts of it (including software) for purposes other than those intended in the accompanying technical documentation;

### 1.3. Technicians and operators

---

The Advanced Power Controller must only be used by personnel qualified for their assigned task, in compliance with the instructions for the task, particularly the relevant safety warnings and precautions.

Qualified personnel, due to their training and experience, are able to recognise the risks involved in use of the instrument and avoid potential hazards.

The Thyritop 600 controllers can be equipped with a Tyritop remote portable programming terminal, powered by the controller, which permits monitoring of process variables and changes of configurations, if necessary, via password.

### 1.1.5. Fieldbus

A Modbus RTU port is always available for connections with the configuration tool or with HMI or PLC devices equipped with Modbus Master communication.

An extensive range of certified Fieldbus options lets you add Thyritop 600 controllers to control architectures with the most popular PLC brands, allowing you to access any device variable with standardised configuration files.

These controls can be combined with softstart ramp functions, with options such as “current limit” to manage current peaks at switch-on and the RMS current value at steady state, thus optimising consumption and increasing the operating life of the load.

### 1.1.6. More

The availability of phase angle (PA) control (the only control method that completely eliminates flickering in IR lamps), combined with current limit and current, voltage or load power feedback functions, means that “critical” applications such as Super-Kanthal™ special heating elements, silicon carbide resistors or single and three phase transformer primaries can be resolved with confidence.

- modify working parameters not accessible to the operator, or decrypt or transfer the software or any of its parts;
- use the instrument in particularly flammable environments;
- repair or modify the instrument using non-original spare parts;
- use the instrument or its parts without having read and correctly interpreted the contents of the accompanying technical documentation;
- dispose of or discard the instrument in common landfills.

In addition, it is assumed that the technicians who commission the instrument and connect it to other units, and those in charge of maintenance, have adequate technical knowledge, particularly in the field of electronics and automation, to fully understand the information provided in this manual.

## 1.4. Thyritop 600



### Main features

- Single/two/three-phase, 40 A to 600 A
- Operating voltages 480 Vac, 600 Vac and 690 Vac
- Firing mode configurable to “Zero crossing” (Fixed Cycle, Burst Firing, Half Single Cycle) and “Phase angle”
- Analogue control inputs configurable to Volt, mA, potentiometer and digital “PWM”
- Three settable retransmission analogue outputs
- Optional inputs from external CTs and VTs
- Softstart and RMS and peak current limits
- V, V<sup>2</sup>, I, I<sup>2</sup> and P feedback
- Total and partial interrupted load alarms with relay outputs
- Built-in fuses
- Temperature sensors on power terminals and cooling air inlet
- Fieldbus: PROFINET, Profibus, Modbus TCP/RTU, Ethernet IP, EtherCAT and CANopen
- Configuration keypad and monitor
- PC configuration tool with setup wizard (SMART)
  - CE, UL, CSA certifications and SCCR UL 508 100KA approvals

### 1.4.1. Main elements of the Thyritop 600, 40 A ... 300 A

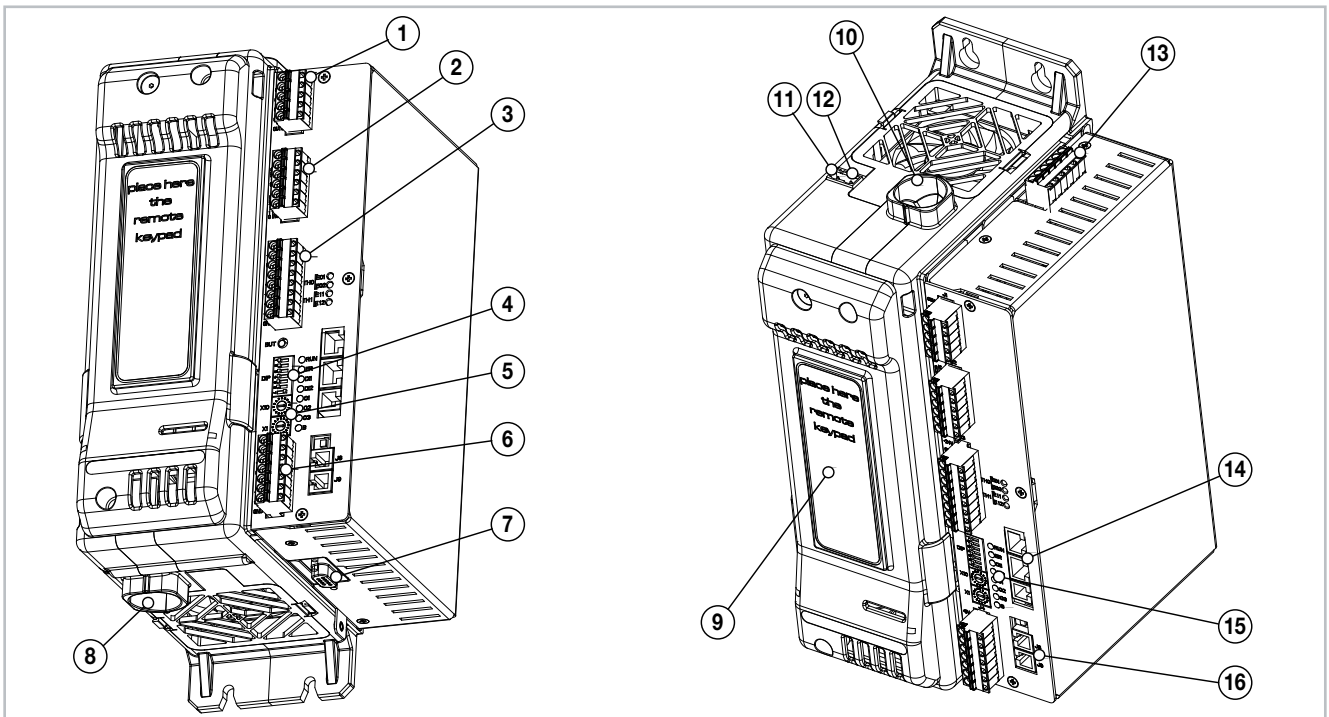

Figure 1 - Elements of the Thyritop 600 40 A ... 300 A models

- |   |  |
|---|--|
| 1. Auxiliary output connector                     | 9. Protective cover on internal fuse and line/load connections |
| 2. Relay output connector                         | 10. Line terminal (pre-split protection grid)                  |
| 3. Power supply connector and 24 V digital inputs | 11. V-load measurement connector                               |
| 4. Dip switch configuration                       | 12. V-line measurement connector                               |
| 5. Rotary switches (addressing)                   | 13. 3-way external CT input connector                          |
| 6. Connector with 3 analogue inputs               | 14. Port2 Fieldbus connectors and LED                          |
| 7. Thyritop 600-OP keypad connector               | 15. Operating status LED                                       |
| 8. Load terminal (pre-split protection grid)      | 16. Port1 RS 485 Modbus RTU                                    |

## 1.4.2. Main elements of the Thyritop 600, 400 A ... 600 A models

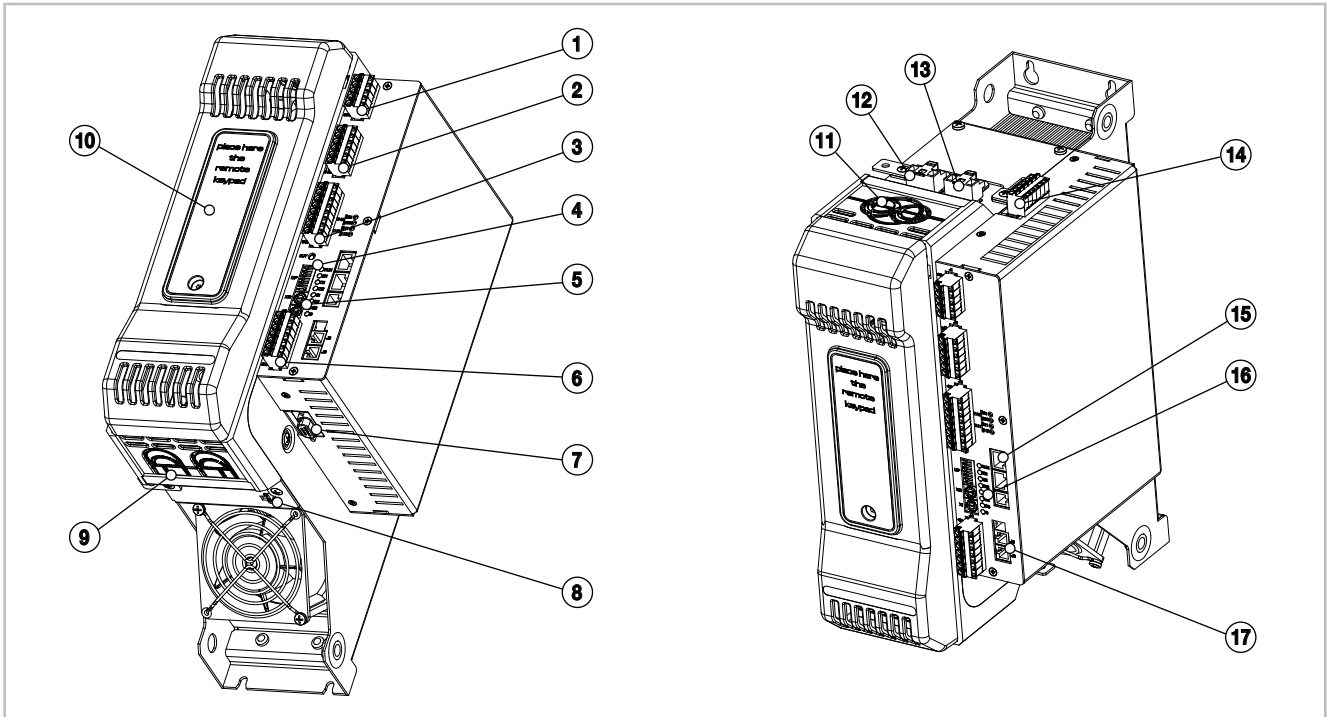
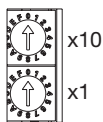

Figure 2 - Elements of the Thyritop 600 400 A ... 600 A models

- |   |   |
|---|---|
| 1. Auxiliary output connector                     | 10. Protective cover on internal fuse and line/load connections |
| 2. Relay output connector                         | 11. Line terminal (pre-split protection grid)                   |
| 3. Power supply connector and 24 V digital inputs | 12. V-load measurement connector                                |
| 4. Dip switch configuration                       | 13. V-line measurement connector                                |
| 5. Rotary switches (addressing)                   | 14. 3-way external CT input connector                           |
| 6. Connector with 3 analogue inputs               | 15. Port2 Fieldbus connectors and LED                           |
| 7. Thyritop 600-OP keypad connector               | 16. Operating status LED  |
| 8. 24 V fan power supply output connector         | 17. Port1 RS 485 Modbus RTU                                     |
| 9. Load terminal (pre-split protection grid)      |   |

## 1.5. Rotary switches



The two hexadecimal rotary switches are used to set the address of the module. Available addresses range from 00...99; hexadecimal combinations are reserved.

The tens selector is identified by **x10** and the units selector by **x1**.

In multi-node operation mode (configuration DIP switch 7 = ON), the selected address is assigned to the Thyritop 600 module only and the expansions, if present, have the following addresses:

Thyritop 600-E1 = address Thyritop 600 + 1  
 Thyritop 600-E2 = address Thyritop 600 + 2



## 1.6. Configuration dip switches

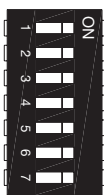

The DIP switches are used to set the configuration of the Advanced Power Controller.

The functions associated with the DIP switches are:

- **DIP switch 1 to 5:** configuration of the type of load connection and presence of a transformer. See paragraph “1.6.1. Type of load connection” for DIP switch settings.
- **DIP switch 6:** loading of the default values for the configuration selected with DIP switches 1 to 7. See paragraph “1.6.2. Initialisation procedure and loading of default values” for the sequence of operations to be carried out.
- **DIP switch 7:** multi-node addressing enabled, if ON.

### 1.6.1. Type of load connection

The table shows the settings of DIP switches 1...5 depending on the load to be controlled.

DIP 1	DIP 2	DIP 3	DIP 4	DIP 5 *	Type of load connection	HW configuration		
						TH600-1PH	TH600-2PH	TH600-3PH
OFF	OFF	OFF	OFF	OFF/ON	1 single-phase load	■	■	■
					2 single-phase loads		■	■
					3 single-phase loads			■
OFF	ON	OFF	OFF	OFF	3 independent single-phase open delta loads			■
ON	ON	OFF	OFF	OFF	Three-phase open delta load			■
					Three-phase star load with neutral			■
ON	ON	ON	OFF	OFF/ON	Three-phase closed delta load			■
ON	OFF	OFF	ON	OFF/ON	Three-phase star load without neutral			■
ON	OFF	OFF	OFF	OFF/ON	Three-phase star load without neutral with TWO-PHASE control		■	
ON	OFF	ON	OFF	OFF/ON	Three-phase closed delta load with TWO-PHASE control		■	

DIP 5 \* : **OFF** = Resistive Load  
**ON** = Inductive load (transformer)

### 1.6.2. Initialisation procedure and loading of default values



**IMPORTANT!** After setting the desired configuration with the DIP switches, perform the following initialisation procedure once.

With the device switched off:

1. Check that DIP switches 1-2-3-4-5-7 are set correctly.
2. Set DIP switch 6 to ON.
3. Power the device with 24 VDC.
4. Wait for the green LED (RUN) to flash regularly.
5. Set DIP switch 6 to OFF.

The configuration is correctly activated.



## 1.7. LED indicator functions

LED	Colour	Description
RN	green	Run: flashing during regular operation
ER	red	Error status: activated in the presence of an alarm
DI1	yellow	Digital input 1 status
DI2	yellow	Digital input 2 status
O1	yellow	Out 1 Master module (M) power output status
O2	yellow	Out 2 expansion 1 (E1) power output status, managed only with Thyritop 600 versions 2PH and 3PH
O3	yellow	Out 3 expansion 2 (E2) power output status, managed only with Thyritop 600 version 3PH
BUTTON	yellow	HB button status

During normal operation, the status of the LEDs follows the corresponding parameter.

In the following special cases they assume different behaviours to indicate the following states:

LED	Behaviour	Description
RN	On steadily	HB button pressed
RN + ER	Flashing together	Autobaud in progress
ER	Flashing	Reports one or more of the following alarms: <ul style="list-style-type: none"> <li>• OVER_HEAT temperature alarm</li> <li>• TEMPERATURE_SENSOR_BROKEN temperature alarm</li> <li>• SHORT_CIRCUIT_CURRENT alarm</li> <li>• SSR_SAFETY alarm</li> <li>• FUSE_OPEN alarm</li> <li>• INTERLOCK function active (Input DI4 set to OFF)</li> </ul>
ER + Ox	Flashing together	Indicate that the HB or POWER_FAULT alarm is active on module x.
All except DI1	Flashing rapidly	Jumper configuration not provided
All except DI2	Flashing rapidly	30%_UNBALANCED_ERROR alarm (only in three-phase configuration)
All except O1	Flash rapidly	SHORT_CIRCUIT_CURRENT alarm (only in three-phase configuration)
All except O2	Flashing rapidly	TRIPHASE_MISSING_LINE_ERROR alarm (only in three-phase configuration)
All except O3	Flashing rapidly	SSR_SAFETY or HW_OVER_HEAT alarm (only in three-phase configuration)
All except BUTTON	Flashing rapidly	FUSE_OPEN alarm (only in three-phase configuration)

## 1.8. Dimensions

### 1.8.1. Dimensions of Thyritop 600, 40 A ... 300 A models

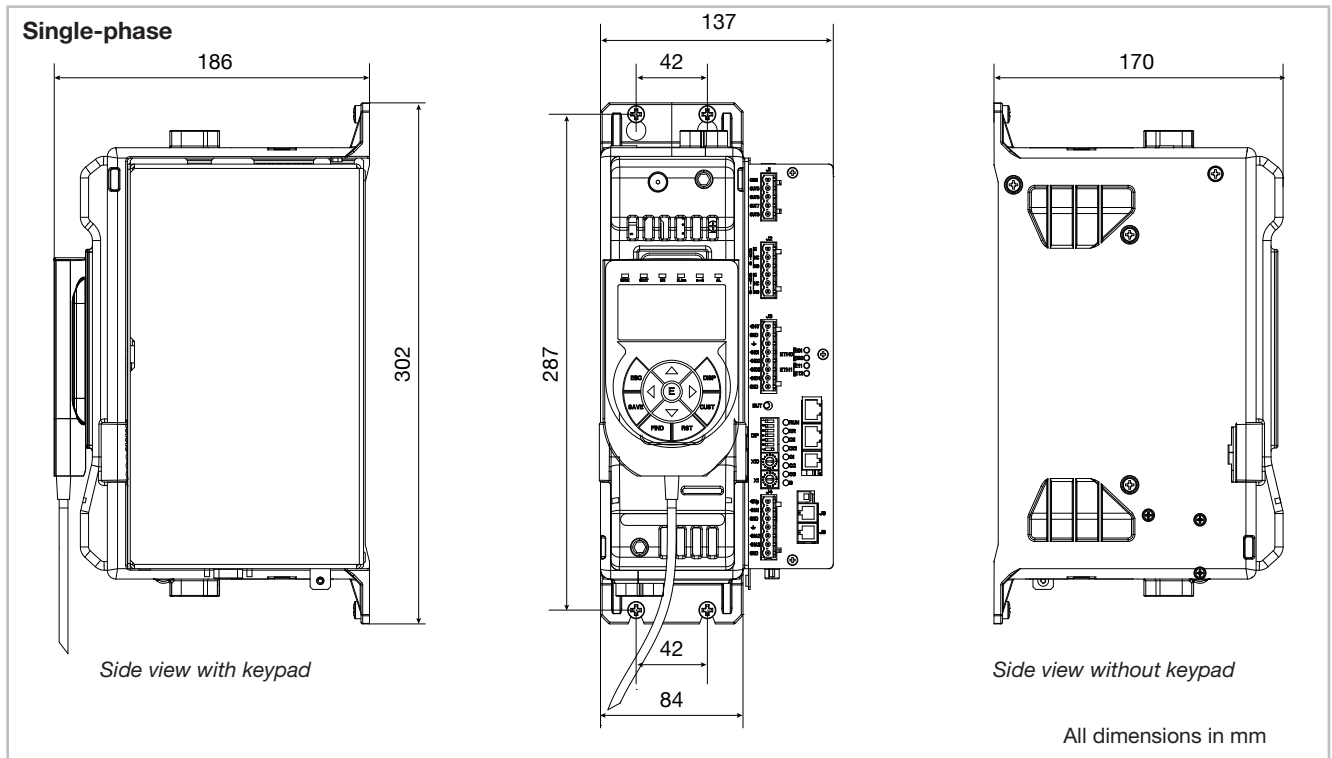

Figure 3 - Dimensions of Thyritop 600 40 ... 300 A (single-phase)

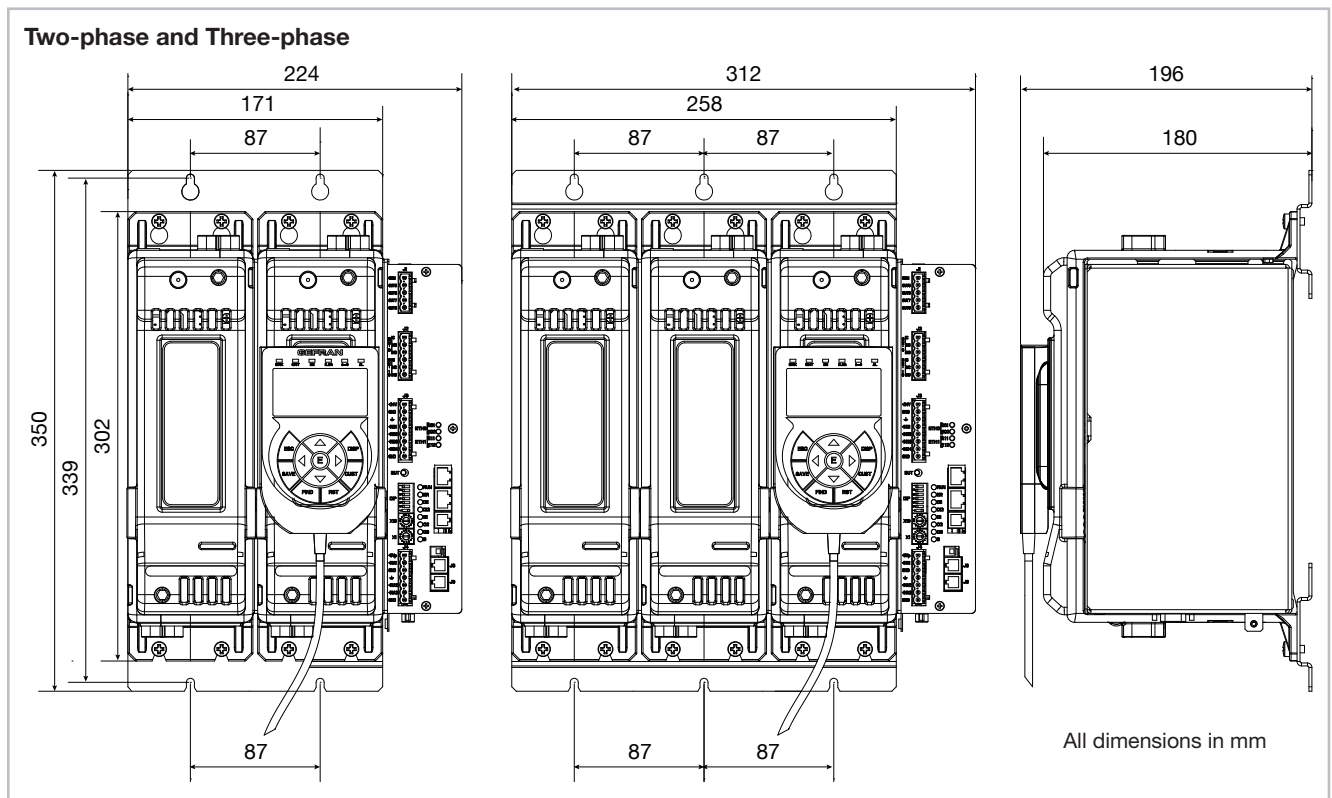

Figure 4 - Dimensions of Thyritop 600 40 ... 300 A (two- and three-phase)

## 1.8.2. Dimensions of Thyritop 600, 400 A ... 600 A

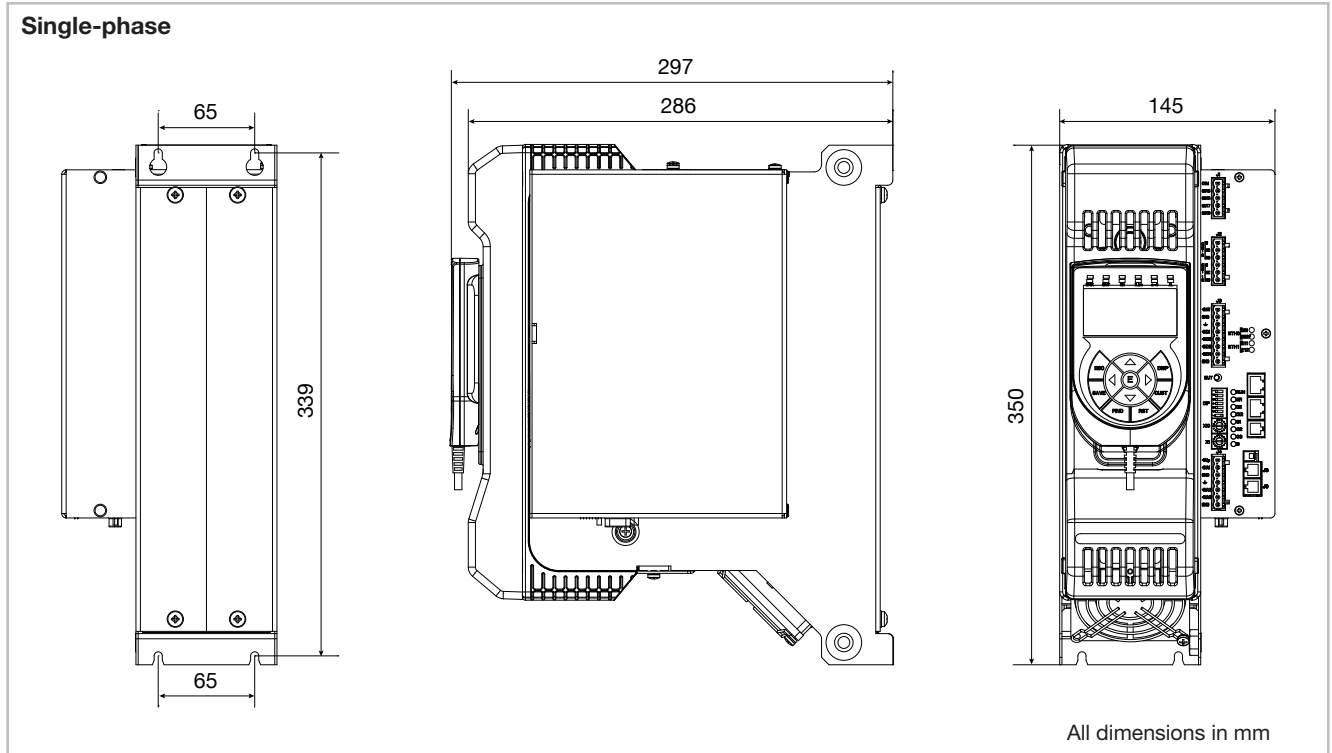

Figure 5 - Dimensions of Thyritop 600 400 ... 600 A (single-phase)

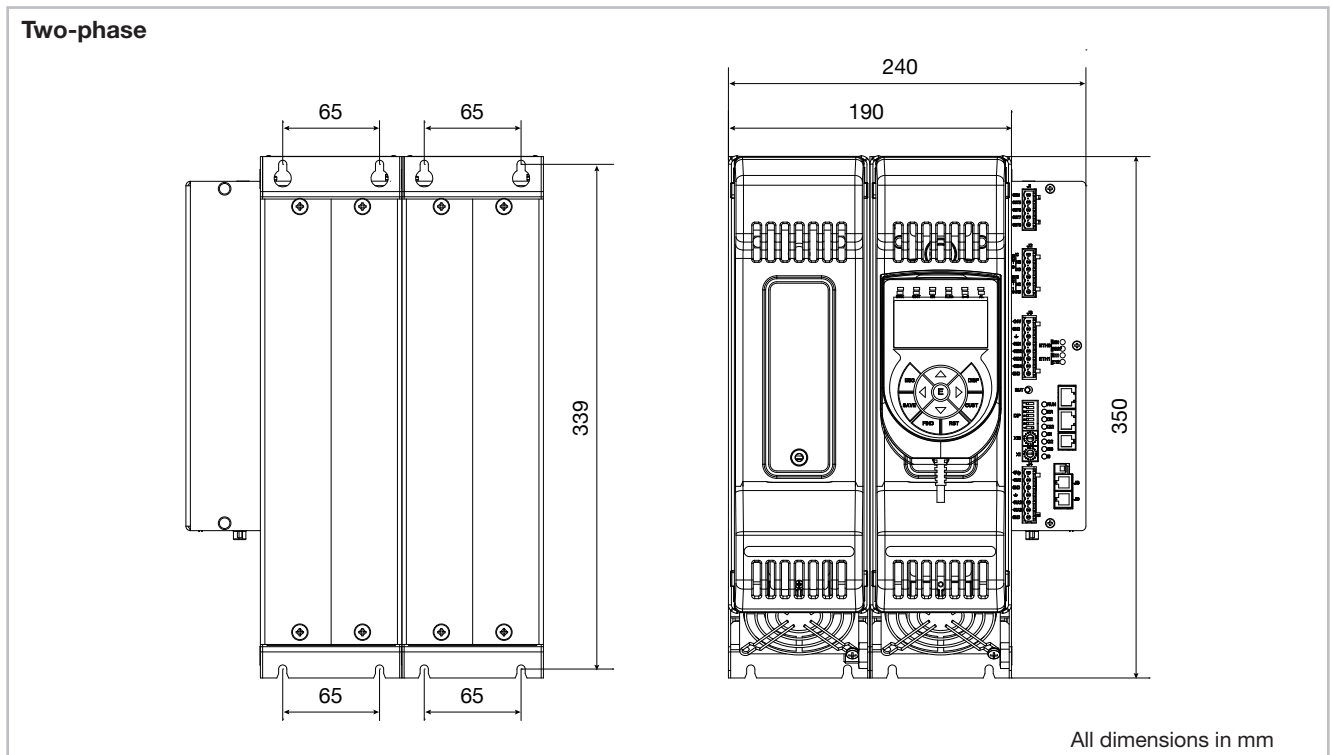
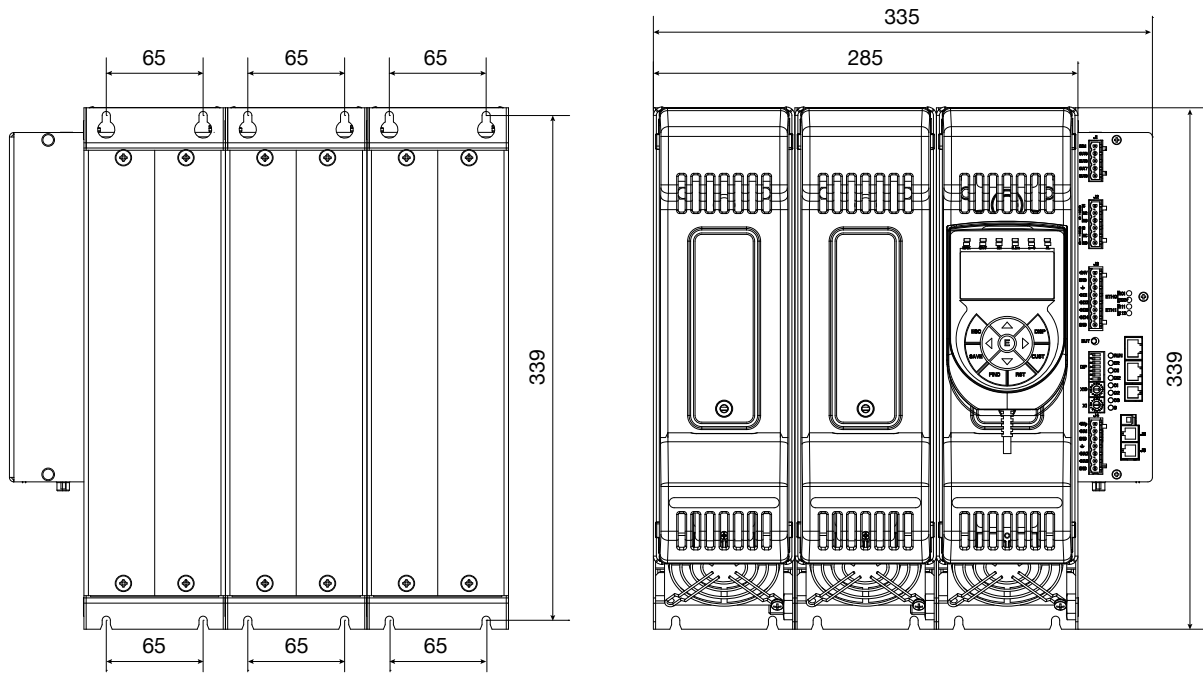

Figure 6 - Dimensions of Thyritop 600 400 ... 600 A (two-phase)

(Three-phase)



All dimensions in mm

Figure 7 - Dimensions of Thyritop 600 400 ... 600 A (three-phase)

## 2. INSTALLATION AND POWER SUPPLY



**Caution!** The installation of the devices described in this manual must be carried out by qualified technicians, following current laws and regulations and in accordance with the instructions given in this manual.

Before installation, check that the controller is intact and has not been damaged during transport. Also ensure that the package contains all the accessories listed in the documentation.

Check that the order code corresponds to the configuration required for the intended use of the controller (rated supply voltage and current, number and type of inputs and outputs). See chapter "8. Order codes" to check the configuration for each order code.



**Caution!** If even one of the above-mentioned requirements (qualified technician, device intact, configuration compatible with needs) is not met, suspend installation and contact your Pyrocontrole dealer or Pyrocontrole Customer Service.

### 2.1. Installing the controller

#### 2.1.1. General installation rules

The Thyritop 600 Advanced Power Controller is designed for permanent indoor installation. It must be installed in electrical panels or in the control panels of machines or production process systems, where the exposed terminals will be protected.



**Caution!** The Advanced Power Controller must NOT be installed in hazardous environments (flammable or explosive atmospheres). It may only be connected to elements operating in such environments by means of suitable types of interfaces, in conformity with the applicable safety standards.



**Caution!** If the Advanced Power Controller is used in applications with risk of damage to persons or property, it must be used in conjunction with dedicated alarm devices. We recommend allowing the possibility to check alarm operation also during normal operation of the controller and the system or equipment being monitored.

The Advanced Power Controller must not be installed where sudden changes in temperature, freezing or condensation can occur or where corrosive gases are present.

The Advanced Power Controller can operate in environments with a pollution degree 2 rating.



**Caution!** Unless adequately protected, the protection rating of the Advanced Power Controller is IP20.

#### 2.1.2. Positioning and minimum ventilation space

To ensure the high reliability of the device, it is essential to install it properly inside the electrical panel so as to ensure an adequate exchange of heat.

Mount the device vertically (maximum 10° inclination from the vertical plane).

The temperature of the compartment containing the Controller must not exceed 50°C for models with rated current from 400 A to 600 A and 40°C for models with rated current from 40 A to 300 A (for higher temperatures, see the derating curves).

Never obstruct the ventilation grills.

Ensure the minimum clearance for adequate air circulation:

- Vertical distance between a device and the panel wall >100 mm
- Horizontal distance between a device and the panel wall at least 10 mm
- Vertical distance between one device and another at least 300 mm.
- Horizontal distance between one device and another at least 10 mm.

See "Figure 8 - Thyritop 600 minimum ventilation spaces".

Ensure that these distances are not reduced by cable ducting. If necessary, mount the units away from the panel wall so that the air can flow vertically without obstruction.

#### 2.1.3. Fixing to the electrical panel

The fixing to the electrical panel is made via the slots at the top and bottom of the controller.

Use M5 screws or bolts or equivalent.

The following illustrations show the drilling templates to be used for fixing the controller, depending on the model and configuration (single-phase, two-phase or three-phase).

All measurements are in mm.

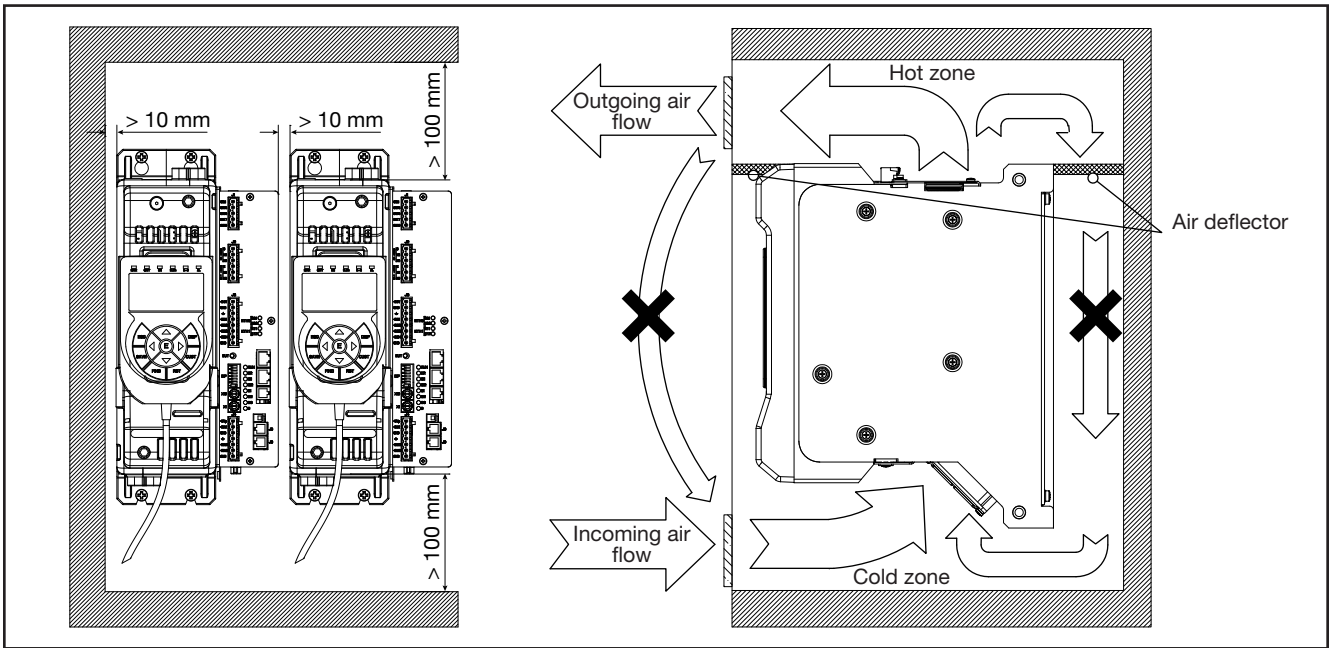

Figure 8 - Thyritop 600 minimum ventilation spaces

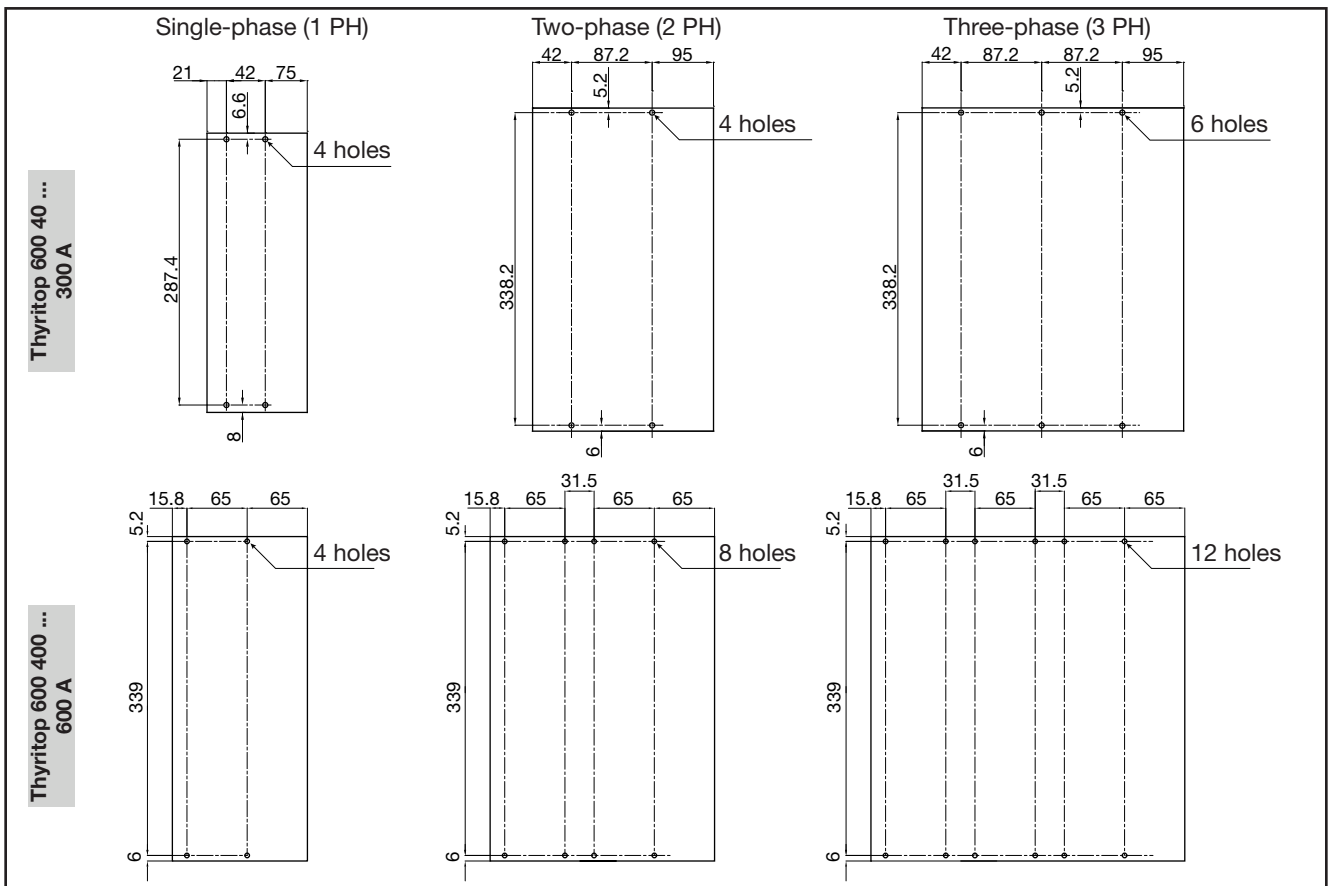

Figure 9 - Thyritop 600 drilling templates



---

## 2.2. Power supply

---

The Advanced Power Controller is NOT supplied with an ON/OFF switch.

It is the responsibility of the user to provide a switch or disconnecter compliant with the applicable safety requirements (CE marking) to disconnect the power supply upstream of the controller.

The switch, or disconnecter, must be placed in the immediate vicinity of the device and be easily accessible to the operator.

A single switch can be used for several controllers.

The Advanced Power Controller must be supplied by a separate line to that used for electromechanical power devices (relays, contactors, solenoid valves, etc.).



**Caution!** The supply must come from a Class II or limited power source.

Suitable mains filters should be used in the vicinity of high-frequency generators or arc welding machines.

A voltage stabiliser should be used if there are large variations in the mains voltage.

Ensure that the earth connection is efficient and made via a specific conductor. A missing or ineffective earth connection can cause unstable device operation due to excessive environmental disturbances.

In particular, check that:

- the voltage between neutral and earth is  $\leq 1$  V;
- the ohmic resistance is  $< 6 \Omega$ .

It is advisable to mount a ferrite core on the supply line, as close to the controller as possible, to limit electromagnetic interference.

The power supply line must be separate from the controller's inputs and outputs.

## 2.3. EMC and LVD conformity

---

### 2.3.1. EMC conformity

The Advanced Power Controller meets the electromagnetic compatibility requirements of Directive 2014/30/EU and subsequent amendments.

EMC conformity has been verified with regard to the information given in Tables 1 and 2.

The Thyritop 600 series of products are mainly intended for use in an industrial environment, installed in switchboards or control panels of machines or production process systems.

The strictest general standards have been applied for electromagnetic compatibility purposes, as shown in the tables below.



**Caution!** The controller is designed for class A equipment. Use in a domestic environment may cause radio interference. In this case, the user may be required to adopt additional attenuation methods.

### 2.3.2. EMC filters

EMC filters are required in PA (Phase Angle, i.e., SCR triggering with a modulated phase angle) operating mode.

The filter model and current size depend on the configuration and the load used. It is important that the power filter is connected as close as possible to the Thyritop 600.

A filter connected between the power supply line and the Thyritop 600 or an LC unit connected between the Thyritop 600 output and the load may be used.

### 2.3.3. LVD or low voltage conformity

The Thyritop 600 complies with the Low Voltage Directive 2014/35/EU.

### 2.3.4. Electrical safety

See table 3 for the standards applied.

<b>EMC emission:</b>		
AC semiconductor motor controllers and conductors for non-motor loads	EN 60947-4-3	
Emission enclosure compliant in firing mode single cycle and phase angle if external filter fitted	EN 60947-4-3 CISPR-11 EN 55011	Class A Group 2

Table 1

<b>EMC Immunity</b>		
Generic standards, immunity standard for industrial environments	EN 60947-4-3	
ESD immunity	EN 61000-4-2	4 kV contact discharge 8 kV air discharge
RF interference immunity	EN 61000-4-3 /A1	10 V/m amplitude modulated 80 MHz-1 GHz 10 V/m amplitude modulated 1.4 GHz-2 GHz
Conducted disturbance immunity	EN 61000-4-6	10 V/m amplitude modulated 0.15 MHz-80 MHz
Burst immunity	EN 61000-4-4	2 kV power line 1 kV I/O signal line
Surge immunity	EN 61000-4-4/5	Power line - line 1 kV Power line - earth 2 kV Signal line - earth 2 kV Signal line - line 1 kV
Magnetic fields immunity	Test is not required. Immunity is demonstrated by the successful completion of the operating capability test.	
Voltage dips, short interruptions and voltage immunity tests	EN 61000-4-11	100%U, 70%U, 40%U,

Table 2

<b>Electrical safety</b>		
Safety requirements for electrical equipment for measurement, control and laboratory use	EN 61010-1/A1	
UL Standard for Safety Industrial Control Equipment	UL 508	

Table 3

## 2.4. Thyritop 600 insulation diagram

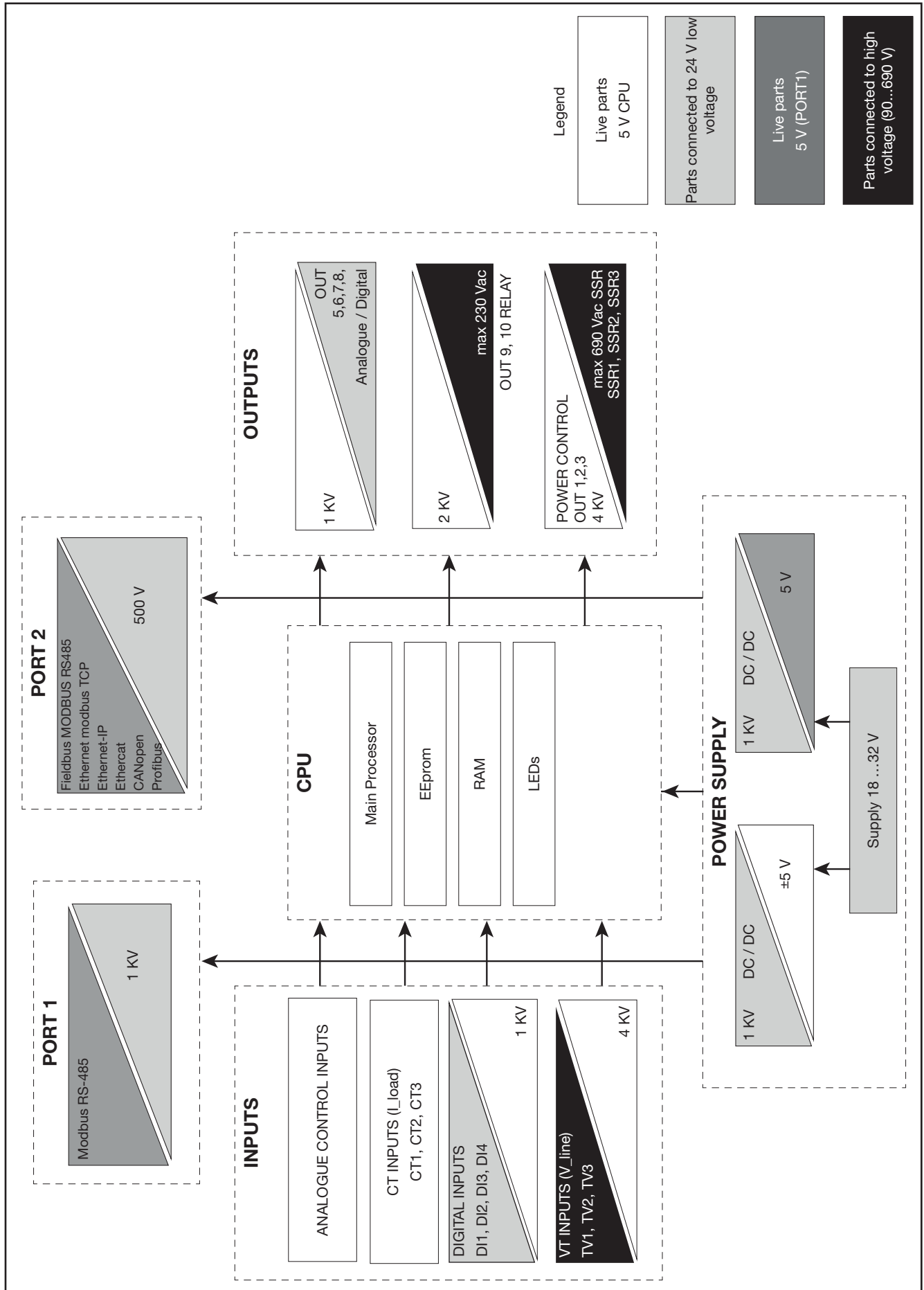

### 3. ELECTRICAL CONNECTIONS



**CAUTION!** Before connecting or disconnecting any connections, check that the power, power supply and control cables are isolated from voltage. External circuits connected must have double insulation. The input cables must be physically separated from those of the power supply, outputs and power connections. Use braided and shielded cables for the inputs, with the sheathing earthed at a single point. Appropriate fuses or automatic circuit breakers must always be provided to protect the power lines. The fuses in the module serve only to protect the semiconductors of the Thyritop 600.

#### 3.1. Description of the connections

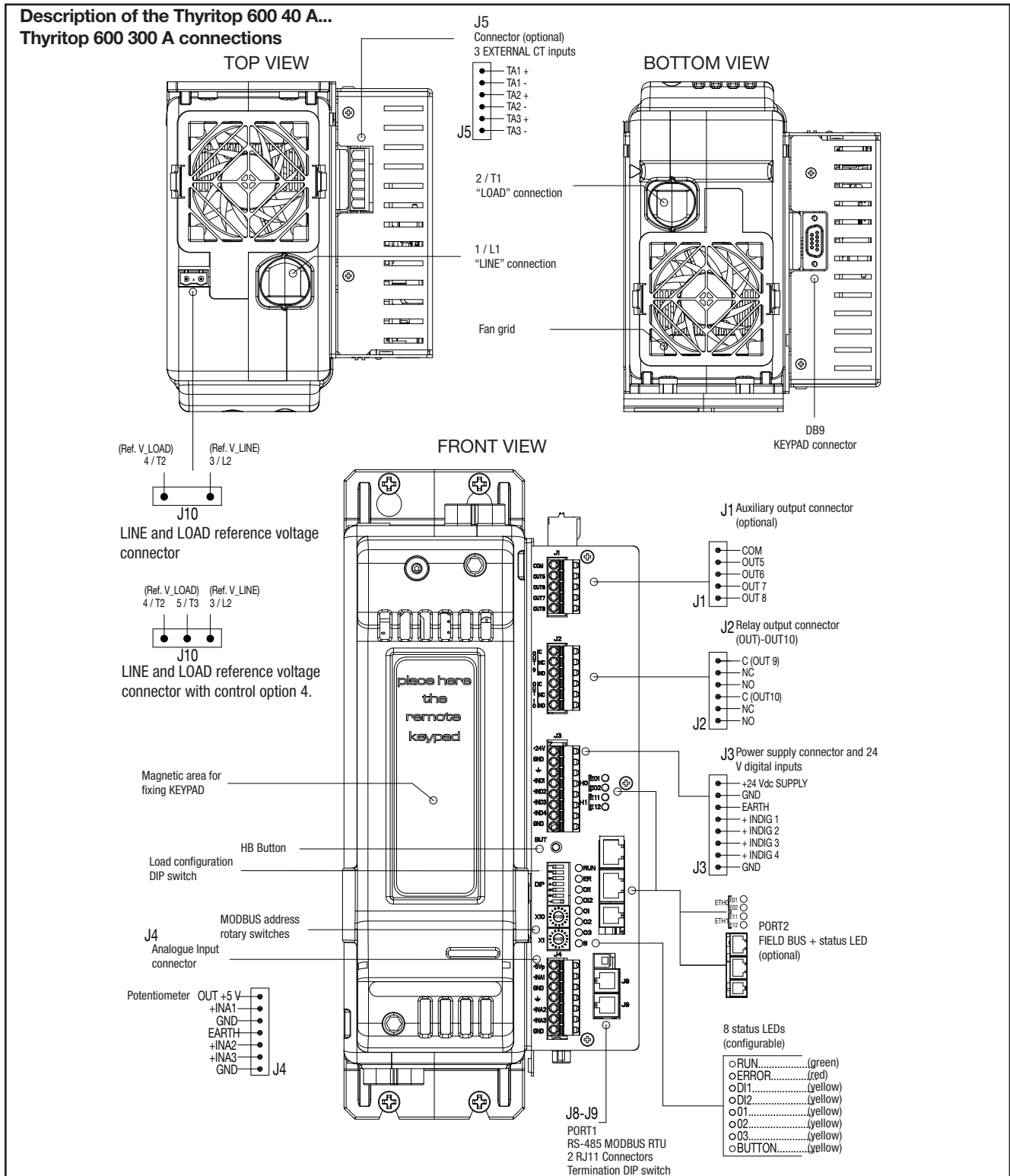

Figure 10 - Description of the Thyritop 600 40 A...Thyritop 600 300 A connections

# Description of the Thyritop 600 400 A...Thyritop 600 600 A connections

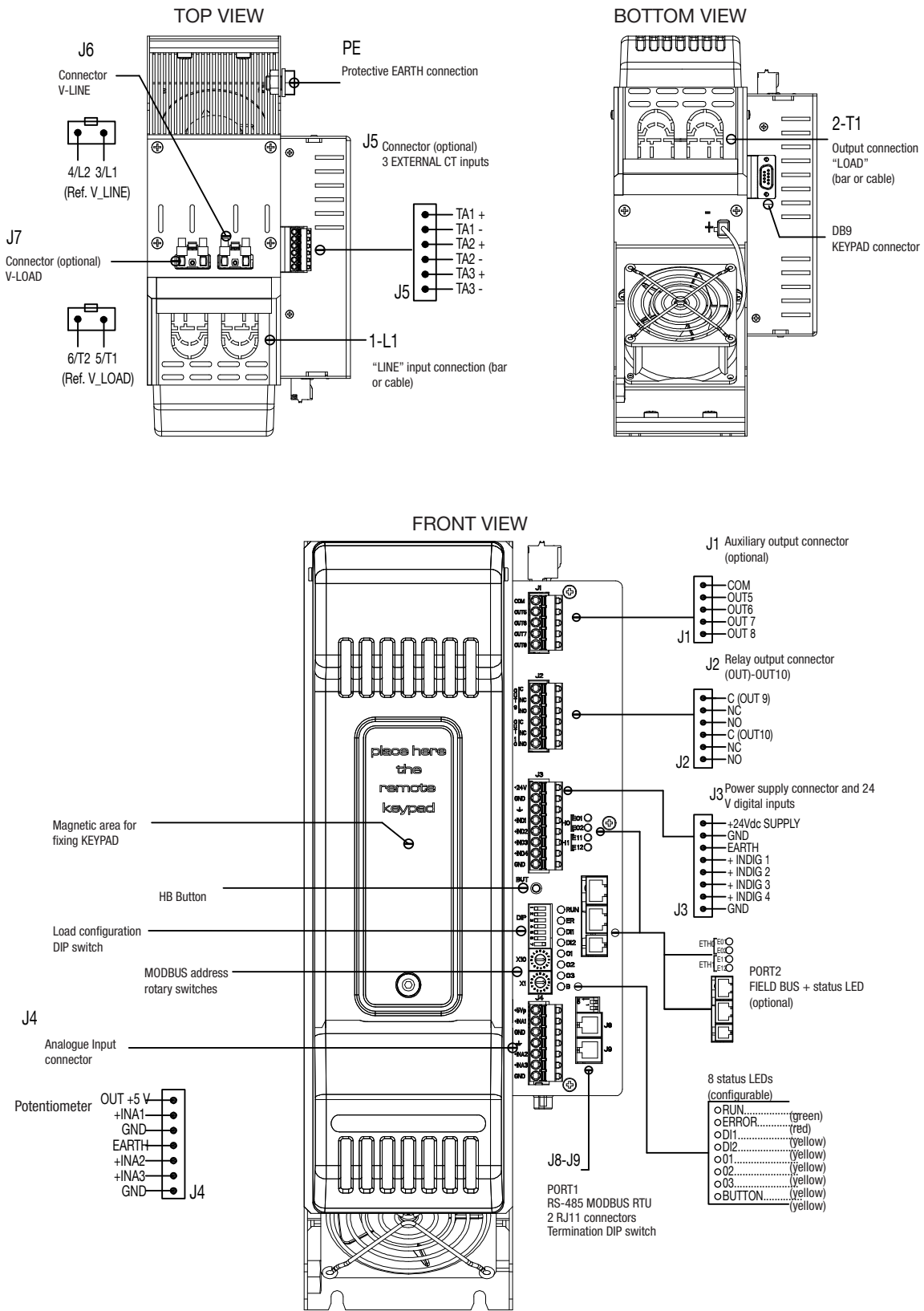

Figure 11 - Description of the Thyritop 600 400 A...Thyritop 600 600 A connections

## 3.2. Inputs

### 3.2.1. J3 connector - Power supply and digital inputs.

The J3 connector includes the power input of the Thyritop 600 controller and 4 digital inputs, configurable via software as NPN or PNP.

For permissible voltages and currents see the Technical Data.

Use cables with a cross-section of 0.25...2.5 mm<sup>2</sup> (23-14 AWG) terminated with ferrules for connection.

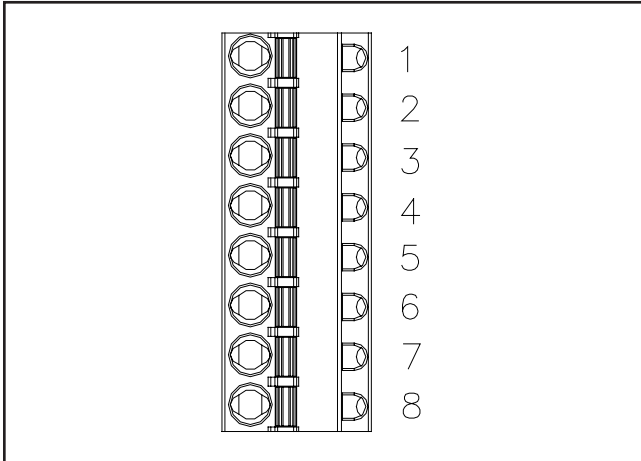

PIN	Name	Description
1	+24 Vdc	Power supply 24 Vdc
2	GND	
3	Earth	Earth EMC
4	+INDIG1	Digital input 1 configurable ON / OFF  <b>Warning!</b> This input can be configured by default as PNP with an active INTERLOCK function. With the INTERLOCK function active, the input must be set to 1 to enable the power outputs.
5	+INDIG2	Digital input 2 configurable NPN / PNP
6	+INDIG3	Digital input 3 configurable NPN / PNP
7	+INDIG4	Digital input 4 configurable NPN / PNP
8	GND	GND common

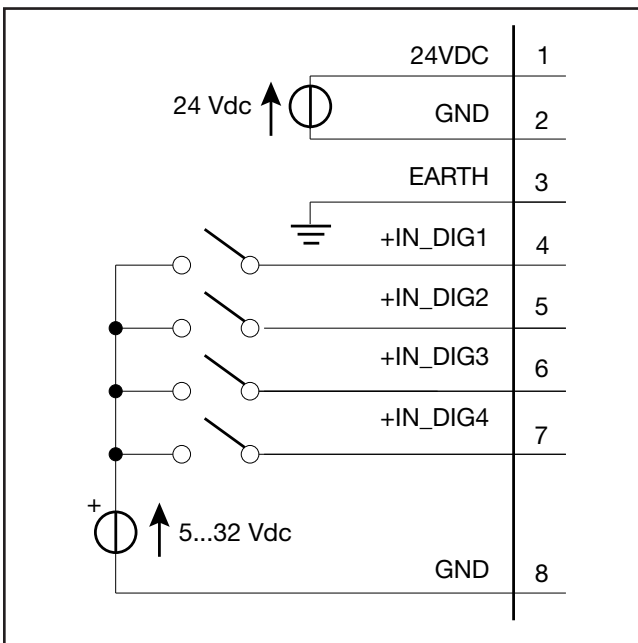

Figure 12 - Power supply and PNP input connection diagram

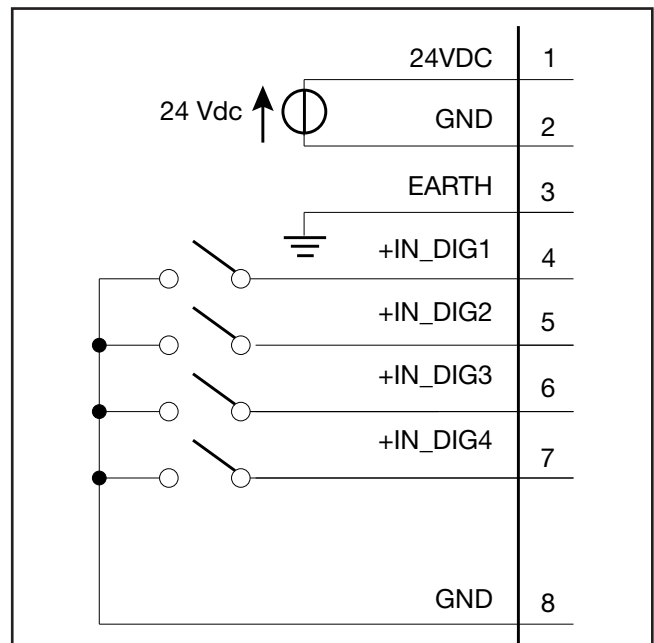

Figure 13 - Power supply and NPN input connection diagram



### 3.2.2. J4 Connector - Analogue control inputs

The J4 connector includes 3 analogue inputs, configurable via software as:

- Voltage input 0...10 V
- Voltage input 0...5 V
- Potentiometer input
- Current input 0...20 mA
- Current input 4...20 mA

For technical specifications, see the Technical Data.

Use shielded cables with a cross-section of 0.25...2.5 mm<sup>2</sup> (23-14 AWG) terminated with ferrules for connection.

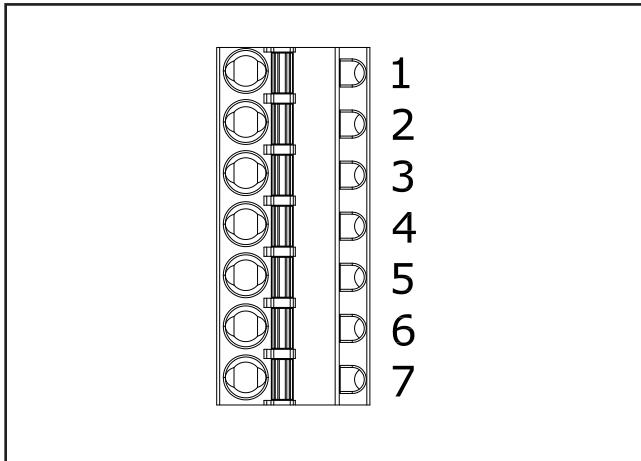

PIN	Name	Description
1	+5V_POT	5 V output for potentiometer power supply
2	+INA1	Analogue command input INA1
3	GND	GND command signal
4	EARTH	Earth EMC
5	+INA2	Analogue command input INA2
6	+INA3	Analogue command input INA3
7	GND	GND command signal

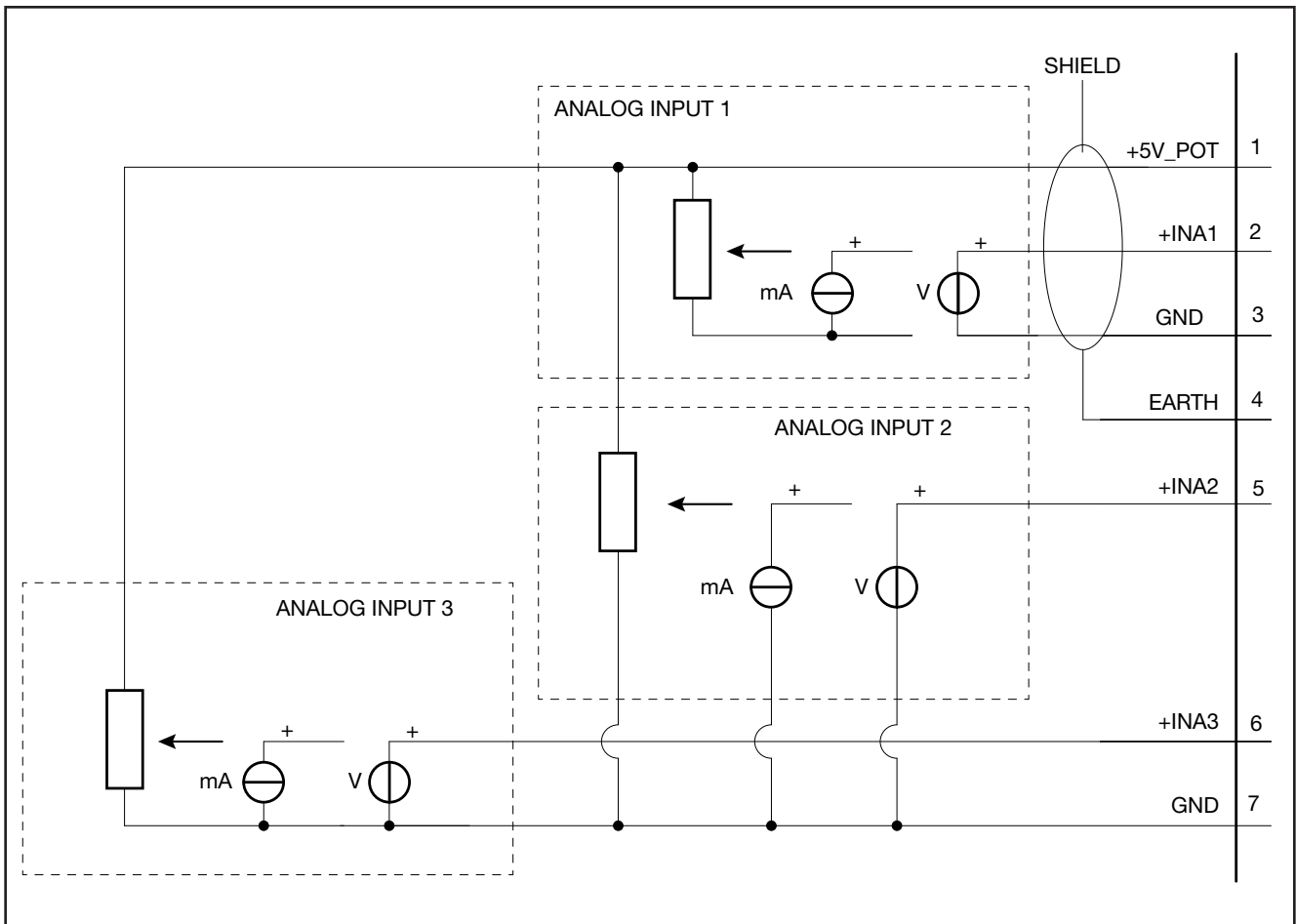
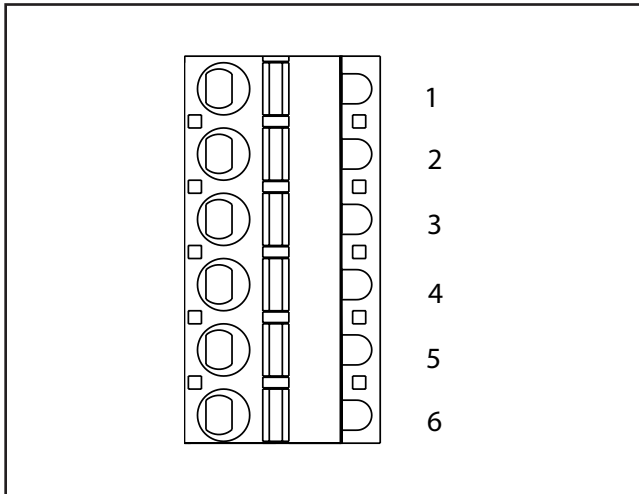

Figure 14 - Analogue input connection diagram

### 3.2.3. J5 connector - External CT inputs (optional)

The J5 connector is only present if the product is equipped with control option 4, which has 3 external CT inputs. For technical specifications, see the Technical Data. Use shielded cables with a cross-section of 0.25...2.5 mm<sup>2</sup> (23-14 AWG) terminated with ferrules for connection.



PIN	Name	Description
1	TA1+	TA1 external input (max 5 A rms)
2	TA1-	
3	TA2+	TA2 external input (max 5 A rms)
4	TA2-	
5	TA3+	TA3 external input (max 5 A rms)
6	TA3-	

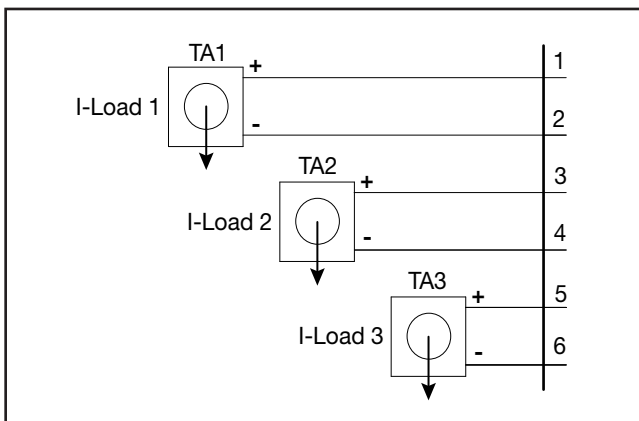

Figure 15 - External CT input connection diagram

### 3.3. Outputs

#### 3.3.1. J1 connector - outputs 5...8 (optional)

The J1 connector is only present if the product is equipped with the optional auxiliary outputs (O5...O8).

The available outputs can be relay type (R), digital type (D) or analogue type (W).

For technical specifications, see the Technical Data.

Use shielded cables with a cross-section of 0.25...2.5 mm<sup>2</sup> (23-14 AWG) terminated with ferrules for connection. A shielded cable is recommended for analogue outputs (W).

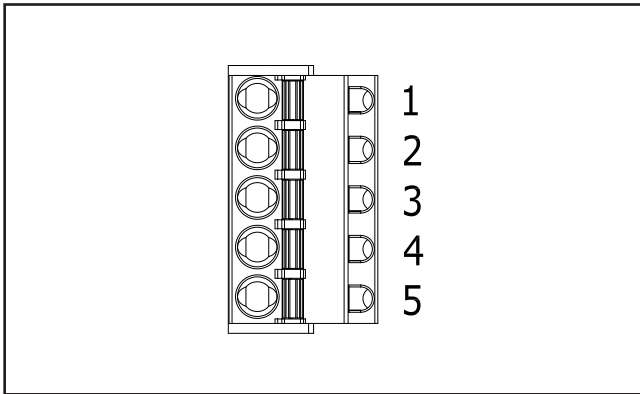

##### 3.3.1.1. Optional D-type outputs (digital)

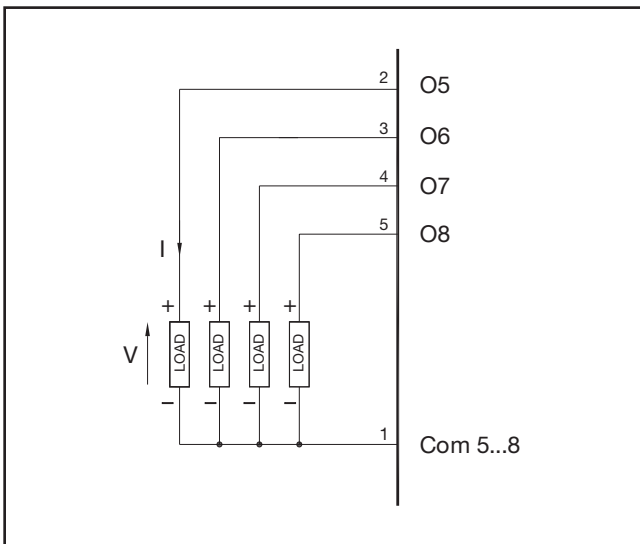

Figure 16 - Digital output connection diagram

PIN	Name	Description
1	Com 5-8	Outputs common
2	O5	Output 5 (+)
3	O6	Output 6 (+)
4	O7	Output 7 (+)
5	O8	Output 8 (+)

Option D includes 4 digital high-side current-emitting outputs. The voltage levels range from 0 V to the product supply value.

### 3.3.1.2. Optional outputs type W (analogue)

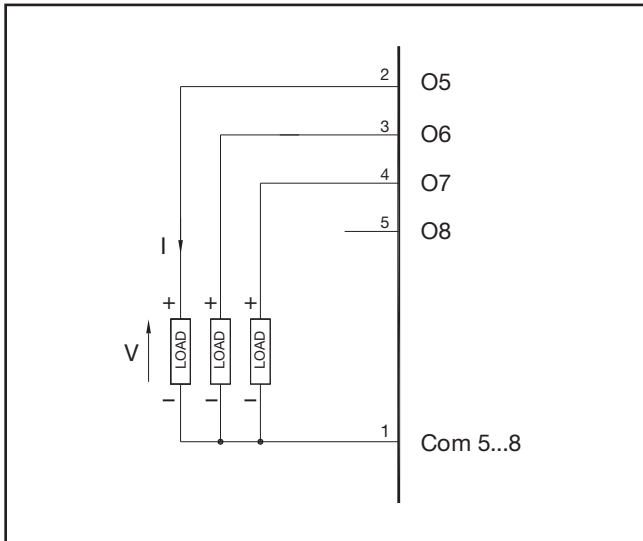

Figure 17 - Analogue output connection diagram

PIN	Name	Description
1	Com 5-8	Common outputs
2	O5	Output 5 (+)
3	O6	Output 6 (+)
4	O7	Output 7 (+)
5	O8	Not used

Option W includes 3 analogue 12-bit outputs configurable via software in:

- Voltage 0...10 V
- Voltage 2...10 V
- Current 0...20 mA
- Current 4...20 mA (default)

### 3.3.1.3. Optional outputs type R (relays)

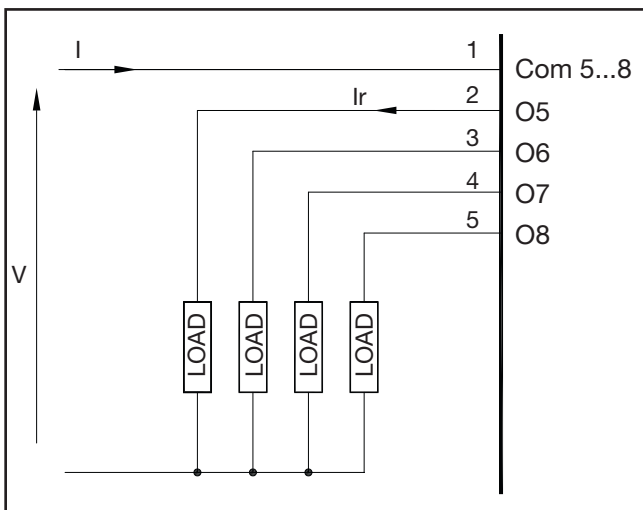

Figure 18 - Relay output connection diagram

PIN	Name	Description
1	Com 5-8	Common outputs
2	O5	Output 5
3	O6	Output 6
4	O7	Output 7
5	O8	Output 8

Option R includes 4 NO relay outputs with a single common.

### 3.3.2. J2 connector - outputs 9 and 10 (relay type)

Outputs 9 and 10 are 2 relay outputs with changeover contact (C - NC - NO).

For technical specifications, see the Technical Data.

Use cables with a cross-section of 0.25...2.5 mm<sup>2</sup> (23-14 AWG) terminated with ferrules for connection.

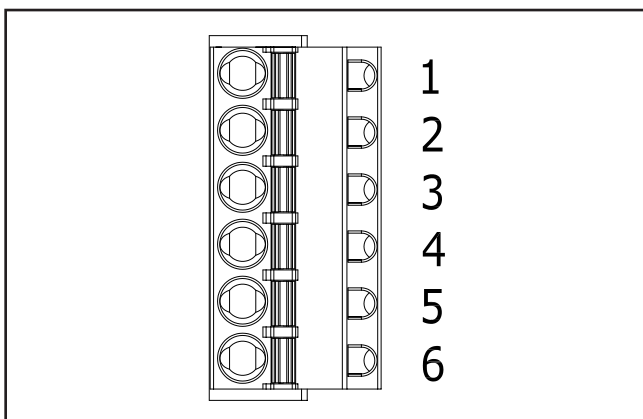

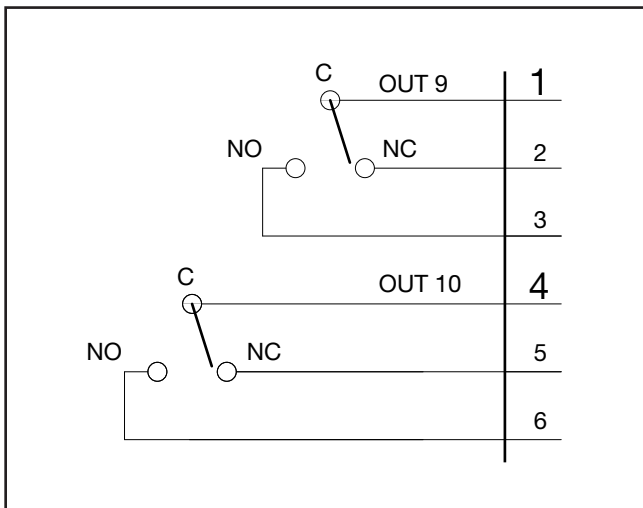

PIN	Name	Description
1	C (Out 9)	Common contact of OUT9
2	NC (Out 9)	Normally closed contact of OUT9
3	NO (Out 9)	Normally open contact of OUT9
4	C (Out 10)	Common contact of OUT10
5	NC (Out 10)	Normally closed contact of OUT10
6	NO (Out 10)	Normally open contact of OUT10

Figure 19 - Outputs 9 and 10 connection diagram

### 3.4. Serial communication port

#### 3.4.1. Location of the ports

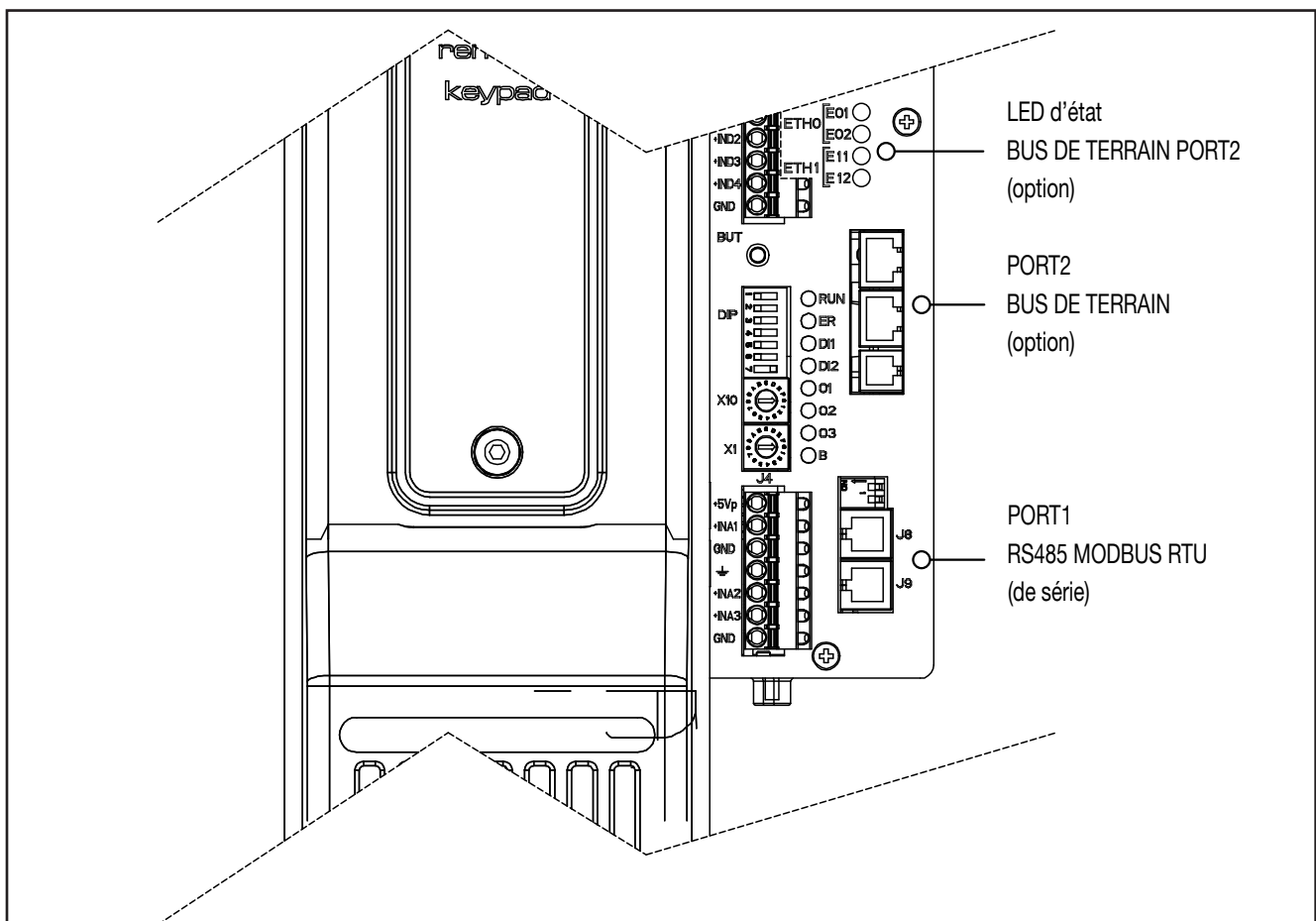

### 3.4.2. PORT1 (local bus): Modbus serial interface - connectors J8 and J9

Port fitted as standard on all Thyritop 600 family.

RS-485 Modbus RTU serial interface, J8 and J9 connectors and DIP switch for line termination.

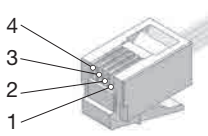
J8/J9 connector RJ10 4-4 plug	Pin	Name	Description	Cable type
	1	GND1 *		Flat telephone cable for 28AWG 4-4 conductor plug
	2	Tx/Rx+	Data reception/transmission (A+)	
	3	Tx/Rx-	Data reception/transmission (B-)	
	4	+V (reserved)		

**Notes**

\*) It is recommended to also connect the GND signal between Modbus devices with a line distance > 100 m.

It is recommended to insert the RS-485 line termination in the last device on the Modbus line via the appropriate DIP switch.

### 3.4.3. PORT2 (optional Fieldbus) type M: Modbus RTU / Modbus RTU - connectors S4, S5

Port only present on Thyritop 600 controllers with Fieldbus option Port 2 = M.

RS-485 Modbus RTU / Modbus RTU serial interface, S4 and S5 connectors and DIP switch for line termination.

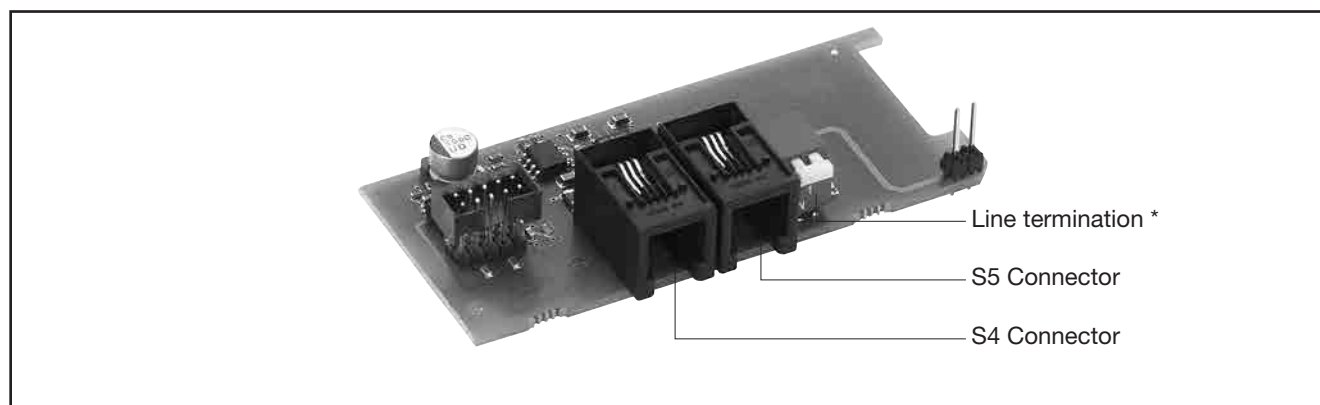

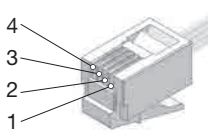
Cable connector for S4/S5 port RJ10 4-4 plug	Pin	Name	Description	Cable type
	1	GND1 **		Flat telephone cable for 28AWG 4-4 conductor plug
	2	Tx/Rx+	Data reception/transmission (A+)	
	3	Tx/Rx-	Data reception/transmission (B-)	
	4	+V (reserved)		

**NB:**

\*) It is recommended to insert the RS-485 line termination in the last device on the Modbus line via the appropriate DIP switch.

\*\*\*) It is recommended to also connect the GND signal between Modbus devices with a line distance > 100 m.



### 3.4.4. PORT2 (optional Fieldbus) type P: Modbus RTU / Profibus DP - connectors S4, S5

Port only present on Thyritop 600 controllers with Fieldbus option Port 2 = P.

RS-485 Modbus RTU / Profibus DP serial interface, S4 and S5 connectors and Profibus communication status LED.

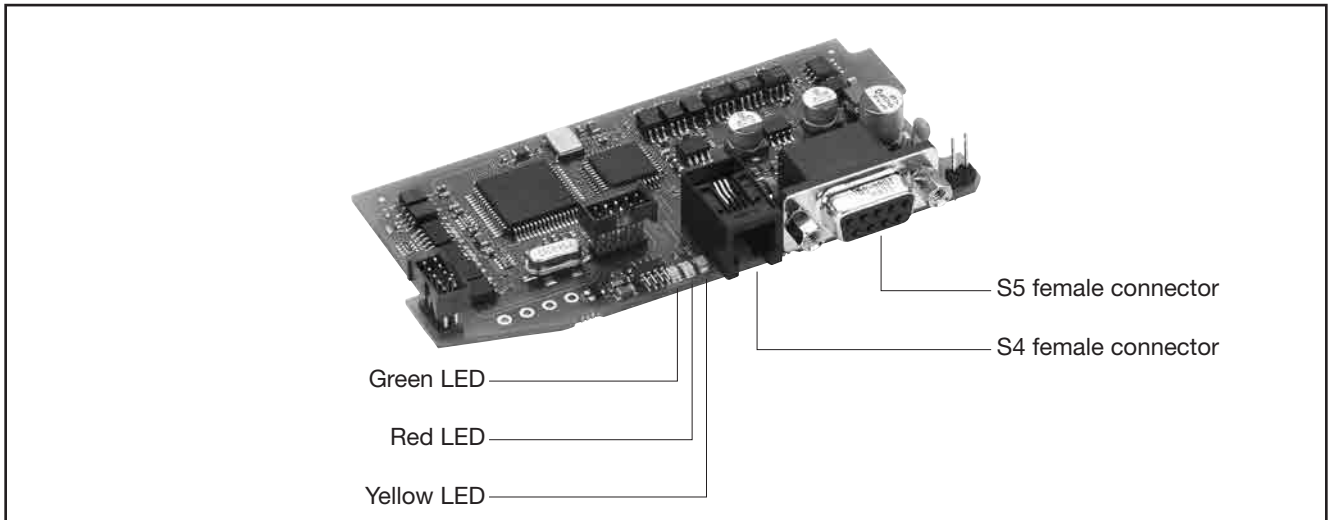

Cable connector for S4/S5 port RJ10 4-4 plug	Pin	Name	Description	Cable type
	1	GND1 *		Flat telephone cable for 28AWG 4-4 conductor plug
	2	Tx/Rx+	Data reception/transmission (A+)	
	3	Tx/Rx-	Data reception/transmission (B-)	
	4	+V (reserved)		

**NB:**  
\*) It is recommended to also connect the GND signal between Modbus devices with a line distance > 100 m.

Cable connector for S5 port D-SUB 9-pole male	Pin	Name	Description	Cable type
	1	SHIELD	EMC protection	Shielded 1 pair 22AWG conductors, PROFIBUS compliant
	2	M24V	Output voltage - 24 V	
	3	RxD / TxD-P	Data reception/transmission	
	4	n.c.	Not connected	
	5	DGND	Data ground	
	6	PV	Positive voltage +5 V	
	7	P24V	Output voltage +24 V	
	8	RxD / TxD-N	Data reception/transmission	
	9	n.c.	Not connected	

**Notes**  
It is recommended to connect the termination resistors as shown in the figure.

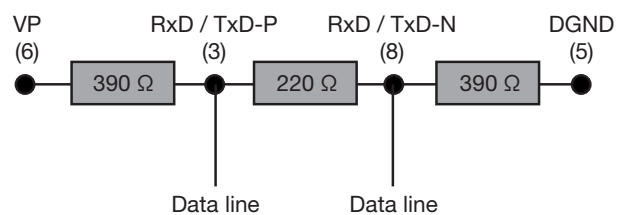

### 3.4.5. PORT2 (optional Fieldbus) type C: Modbus RTU / CANopen - connectors S4, S5

Port only present on Thyritop 600 controllers with Fieldbus option Port 2 = C.

RS-485 Modbus RTU / CANopen serial interface, S4 and S5 connectors and CANopen communication status LED.

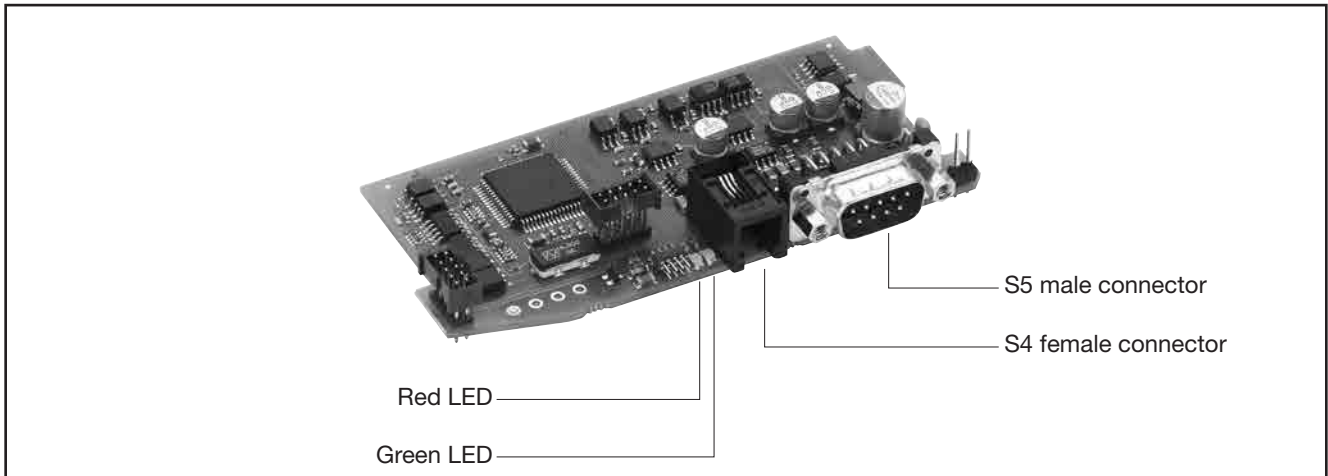

Cable connector for S4 port RJ10 4-4 plug	Pin	Name	Description	Cable type
	1	GND1 *		Flat telephone cable for 28AWG 4-4 conductor plug
	2	Tx/Rx+	Data reception/transmission (A+)	
	3	Tx/Rx-	Data reception/transmission (B-)	
	4	+V (reserved)		

**Notes**

\*) It is recommended to also connect the GND signal between Modbus devices with a line distance > 100 m.

Cable connector for S5 port D-SUB 9-pole female	Pin	Name	Description	Cable type
	1	-	Reserved	Shielded 2 conductor pairs 22/24AWG, conforming to CANopen
	2	CAN_L	CAN_L bus line (domination low)	
	3	CAN_GND	CAN Ground	
	4	-	Reserved	
	5	(CAN_SHLD)	Optional CAN Shield	
	6	GND	Optional Ground	
	7	CAN_H	CAN_H bus line (domination high)	
	8	-	Reserved	
	9	(CAN_V+)	Optional CAN external positive supply (dedicated for supply of transceivers and optocouplers, if galvanic isolation of the bus node applies)	

**Notes**

It is recommended to connect the termination resistors as shown in the figure.

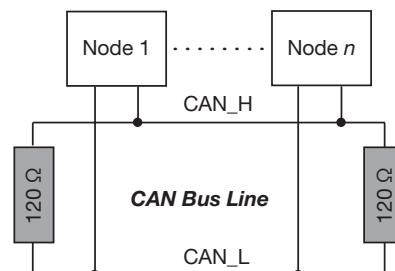

### 3.4.6. PORT2 (optional Fieldbus) type E: Modbus RTU / Ethernet Modbus TCP - connectors S4, S5

Port only present on Thyritop 600 controllers with Fieldbus option Port 2 = E.  
RS-485 Modbus RTU / Ethernet Modbus TCP serial interface, S4 and S5 connectors and status LEDs on CPU front panel.

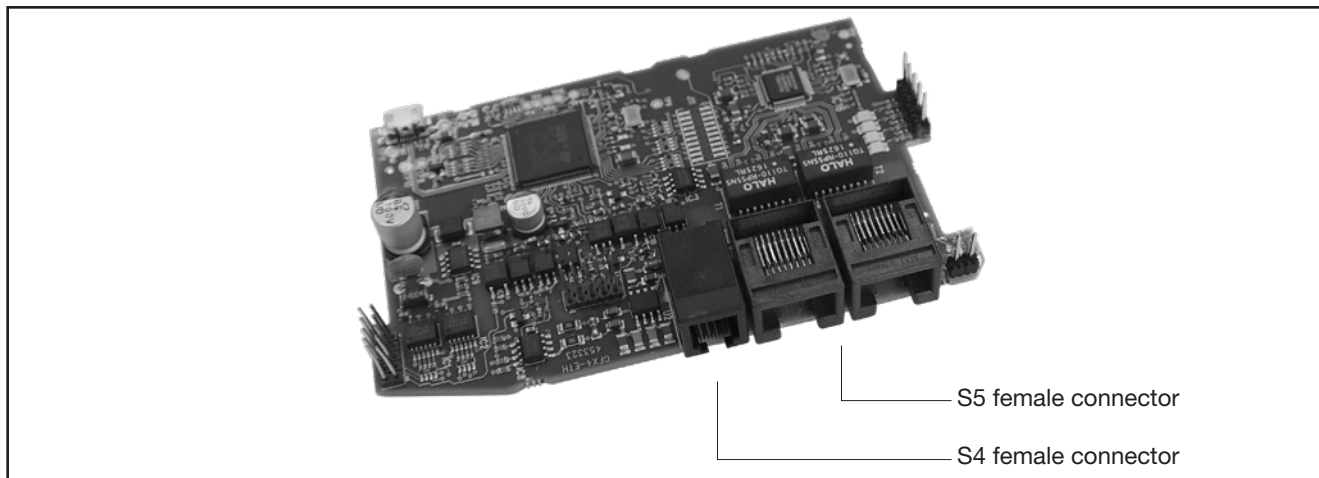

Cable connector for S4 port RJ10 4-4 plug	Pin	Name	Description	Cable type
	1	GND1 *		Flat telephone cable for 28AWG 4-4 conductor plug
	2	Tx/Rx+	Data reception/transmission (A+)	
	3	Tx/Rx-	Data reception/transmission (B-)	
	4	+V (reserved)		

**Notes**

\*) It is recommended to also connect the GND signal between Modbus devices with a line distance > 100 m.

Cable connector for S5 port RJ45 plug	Pin	Name	Description	Cable type
	1	TX+	Data transmission +	Standard cable category 5 or higher in accordance with TIA/ EIA-568B
	2	TX	Data transmission -	
	3	RX	Data reception +	
	4	n.c.	Not connected	
	5	n.c.	Not connected	
	6	RX	Data reception -	
	7	n.c.	Not connected	
	8	n.c.	Not connected	

### 3.4.7. PORT2 (optional Fieldbus) type E6 / E7 / E8 - connectors S4, S5

Port only present on Thyritop 600 controllers with the following options:

- Fieldbus Port 2 = E6 for Modbus RTU / **Profinet** serial interface.
- Fieldbus Port 2 = E7 for Modbus RTU / **EtherCAT** serial interface.
- Fieldbus Port 2 = E8 for Modbus RTU / **Ethernet IP** serial interface.

S4 and S5 connectors and status LEDs on CPU front panel.

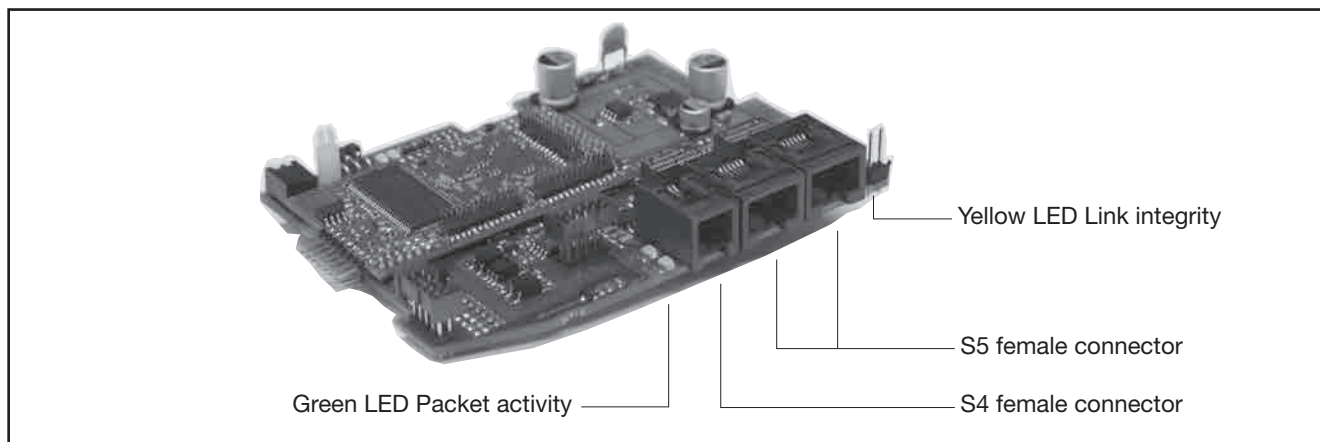

Cable connector for S4 port RJ10 4-4 plug	Pin	Name	Description	Cable type
	1	GND1 *		Flat telephone cable for 28AWG 4-4 conductor plug
	2	Tx/Rx+	Data reception/transmission (A+)	
	3	Tx/Rx-	Data reception/transmission (B-)	
	4	+V (reserved)		

#### Notes

\*) It is recommended to also connect the GND signal between Modbus devices with a line distance > 100 m.

Cable connector for S5 port RJ45 plug	Pin	Name	Description	Cable type
	1	TX+	Data transmission +	Standard cable category 5 or higher in accordance with TIA/EIA-568B
	2	TX	Data transmission -	
	3	RX	Data reception +	
	4	n.c.	Not connected	
	5	n.c.	Not connected	
	6	RX	Data reception -	
	7	n.c.	Not connected	
	8	n.c.	Not connected	

## 3.5. Power connections

### 3.5.1. Recommended cable cross-section with Thyritop 600 40 A ... 300 A

THYRITOP 600 CURRENT LEVEL	TERMINAL	CABLE TYPE/ CROSS-SECTION BAR TYPE/CROSS-SECTION	CABLE/BAR TERMINATION TYPE	TIGHTENING TORQUE / TOOL	FIG.
40 A	1/L1, 2/T1	10 mm <sup>2</sup> (7 AWG)	Wire stripped for 25 mm or with crimped insulated end sleeve Cembre PKC1018	5 N m 1 x 5.5 mm slotted screwdriver	
60 A	1/L1, 2/T1	16 mm <sup>2</sup> (5 AWG)	Wire stripped for 25 mm or with crimped insulated end sleeve Cembre PKC1618		
100 A	1/L1, 2/T1	50 mm <sup>2</sup> (1 AWG)	Wire stripped for 25 mm or with crimped insulated end sleeve Cembre PKC50025		
150 A	1/L1, 2/T1	70 mm <sup>2</sup> (2/0 AWG)	Wire stripped for 25 mm or with crimped insulated end sleeve Cembre PKC70022	6 N m No. 6 hex key	
200 A	1/L1, 2/T1	95 mm <sup>2</sup> (4/0 AWG)	Wire stripped for 25 mm or with crimped insulated end sleeve Cembre PKC95025		
250 A	1/L1, 2/T1	120 mm <sup>2</sup> (250 AWG)	Wire stripped for 25 mm		
300 A	1/L1, 2/T1	185 mm <sup>2</sup> (350 kcmil)	Wire stripped for 25 mm		
	3/L2 4/T2	.25 ...2.5 mm <sup>2</sup> (23...14 AWG)	Wire stripped for 8 mm or with a tag terminal	0.5...0.6 N m 0.6 x 3.5 mm slotted screwdriver	

#### Notes

Cables must be copper 'Stranded Wire' or 'Compact-Stranded Wire' and have a maximum operating temperature of 60/75 °C.

### 3.5.2. Recommended cable cross-section with Thyritop 600 400 A ... 600 A

THYRITOP 600 CURRENT LEVEL	TERMINAL	CABLE TYPE/ CROSS-SECTION BAR TYPE/CROSS-SECTION	CABLE/BAR TERMINATION TYPE	TIGHTENING TORQUE / TOOL	FIG.
400 A	1/L1, 2/T1	Single cable, 300 mm <sup>2</sup> (600 kcmil)	Cable crimped to Cembre A60-M12 lug	x1 Bolt M12x25mm UNI 5739 No. 18 hex key Torque: 50 N m (**) (***)	A
		Double cable, 2 x 95 mm <sup>2</sup> (3/0 AWG)	Cable crimped to Cembre A19-M10 lug	x2 Bolts M10x25mm UNI 5739 No. 17 hex key Torque: 40 N m (***)	B
			Stripped cable for 30 mm inserted in the ILSCO AU-350 lug (Accessory)	x1 Bolt M12x25mm UNI 5739 No. 18 hex key Torque: 50 N m (*)	C
			Copper bar cross-section (WxH): (40x2)-(32x2)-(24x3) mm	Insulated copper bar with non-insulated termination with L= 60-65 mm max.	x1 Bolt M12x25mm UNI 5739 No. 18 hex key Torque: 50 N m
	PE	Cable 95 mm <sup>2</sup> (3/0 AWG)	Cable crimped to Cembre A19-M10 lug	x1 Bolt M10x20mm UNI 5739 No. 17 hex key Torque: 40 N m (***)	E
500 A	1/L1, 2/T1	Double cable, 2 x 120 mm <sup>2</sup> (250 kcmil)	Cable crimped to Cembre A24-M10 lug	x2 Bolts M10x25 mm UNI 5739 No. 17 hex key Torque: 40 N m (***)	F
			Wire stripped for 30mm inserted into ILSCO AU-350 lug (Accessory)	x1 Bolt M12x25 mm UNI 5739 No. 18 hex key Torque: 50 N m (*)	G
		Copper bar cross-section (WxH): (40x3)-(32x4)-(24x5) mm	Insulated copper bar with non-insulated termination with L = 60-65 mm max.	x1 Bolt M12x25 mm UNI 5739 No. 18 hex key Torque: 50 N m	H
	PE	Cable 120 mm <sup>2</sup> (250 kcmil)	Cable crimped to Cembre A24-M10 lug	x1 Bolt M10x20 mm UNI 5739 No. 17 hex key Torque: 40 N m (***)	E
600 A	1/L1, 2/T1	Double cable, 2 x 185 mm <sup>2</sup> (350 kcmil)	Cable crimped to Cembre A37-M10 lug	x2 Bolts M10x25mm UNI 5739 No. 17 hex key Torque: 40 N m (***)	F
			Wire stripped for 30 mm inserted in the ILSCO AU-350 lug (Accessory)	x1 Bolt M12x25mm UNI 5739 No. 18 hex key Torque: 50 N m (*)	G
		Copper bar (WxH) cross-section: (50x4)-(40x4)-(32x5) mm	Insulated copper bar with non-insulated termination with L = 60-65 mm max.	x1 Bolt M12x25mm UNI 5739 No. 18 hex key Torque: 50 N m	H
	PE	Cable 120 mm <sup>2</sup> (250 kcmil)	Cable crimped to Cembre A37-M10 lug	x1 Bolt M10x20mm UNI 5739 No. 17 hex key Torque: 40 N m (***)	E
400, 500, 600 A	J6, J7	Cable 0.25 ... 2.5 mm <sup>2</sup> (23 ...14 AWG)	Wire stripped for 8 mm or with a tag terminal	0.6 ...0.6 N m 0.6 x 3.5 mm slotted screwdriver	

#### Notes

Cables must be copper 'Stranded Wire' or 'Compact-Stranded Wire' and have a maximum operating temperature of 60/75 °C.

(\*) The cables in the ILSCO accessory must be tightened using a No. 8 hex key with a torque of 30 N m.

(\*\*) Use the IP20 grid of the accessory code F067432.

(\*\*\*) Use exclusively UL lugs with their respective crimper.

The figures below and in the table show how to open the pre-fabricated passages according to the type of connection to be made.

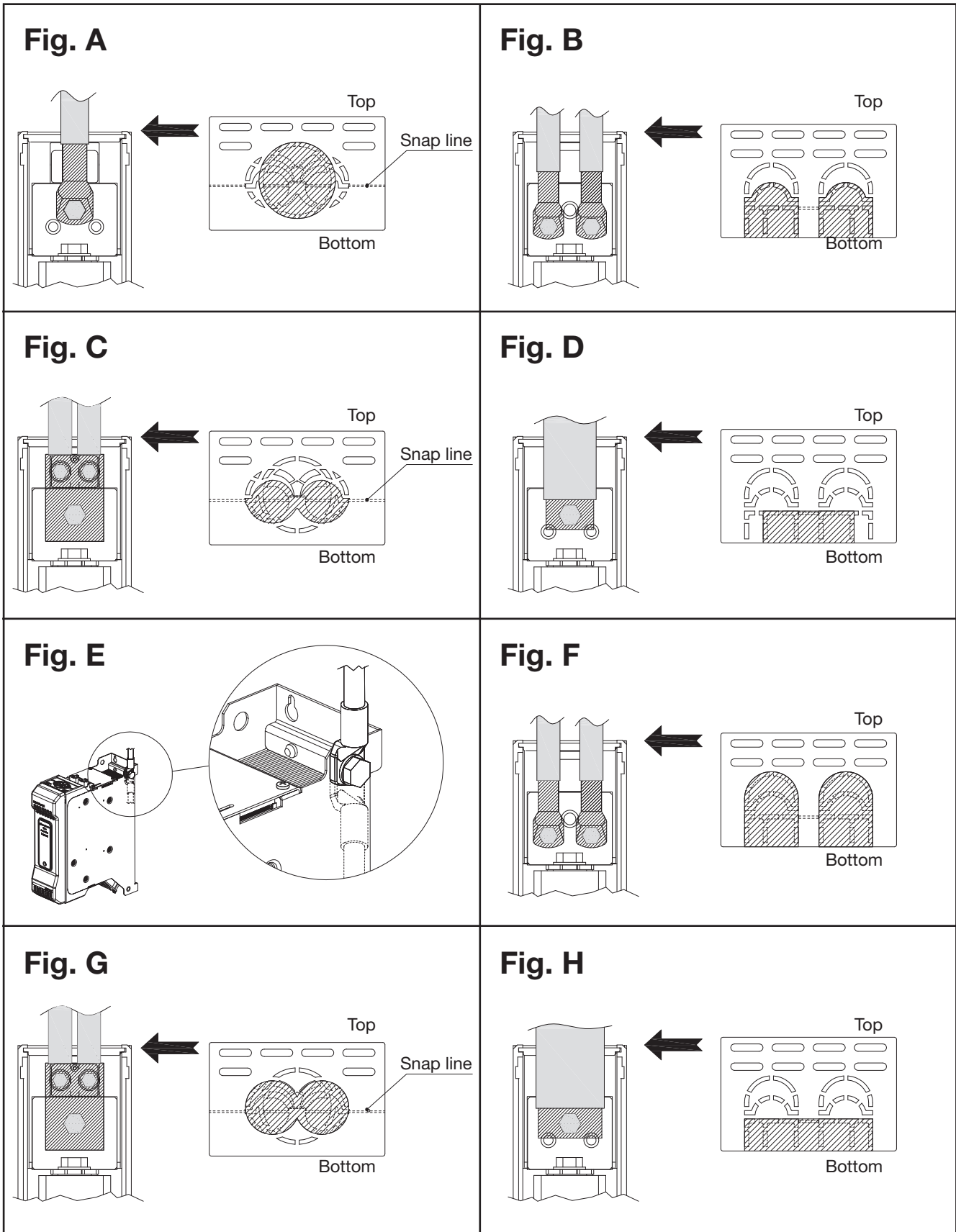

### 3.6. Connection examples - Power section for Thyritop 600 40 A...Thyritop 600 300 A

#### 3.6.1. Connection example for single-phase Thyritop 600 (1PH) for a single-phase load

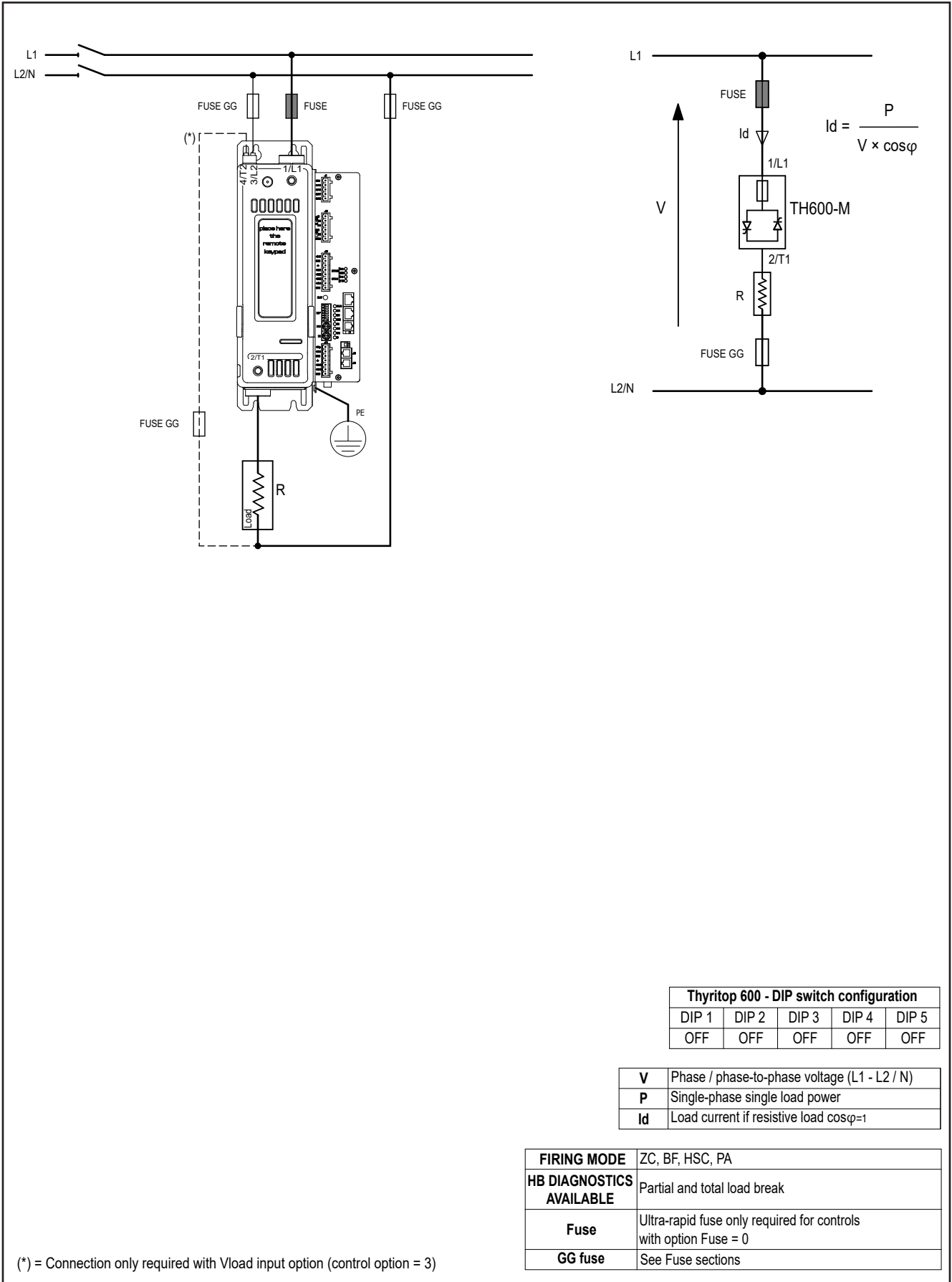



### 3.6.2. Connection example for single-phase Thyritop 600 (1PH) for a single-phase load with transformer

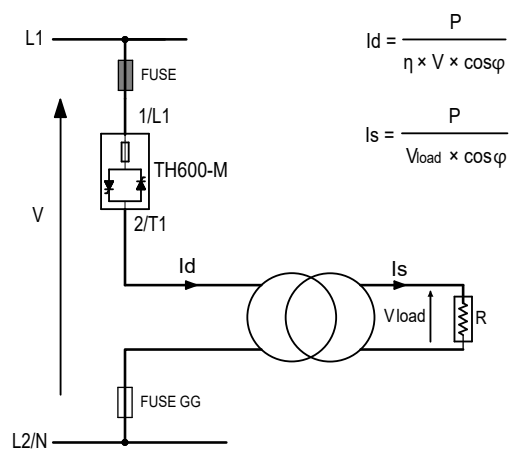
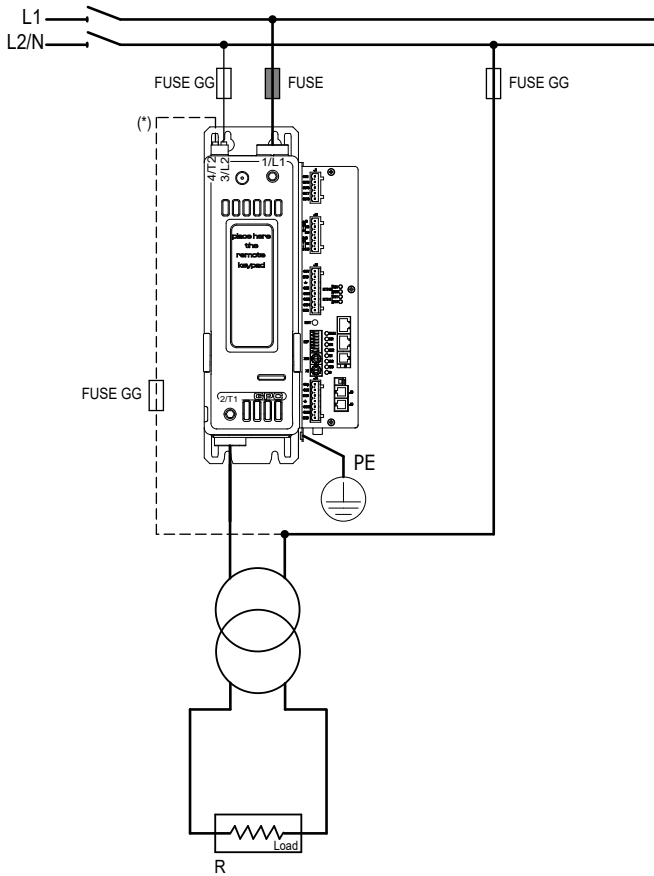

$$I_d = \frac{P}{\eta \times V \times \cos \varphi}$$

$$I_s = \frac{P}{V_{load} \times \cos \varphi}$$

**CAUTION**   
 (\*) =With control option 3,  
 the Vload input cannot be  
 connected to the secondary  
 of the transformer

Thyritop 600 - DIP switch configuration				
DIP 1	DIP 2	DIP 3	DIP 4	DIP 5
OFF	OFF	OFF	OFF	ON

<b>V</b>	Phase / phase-to-phase voltage (L1 - L2 / N)
<b>P</b>	Single-phase single load power
<b>Vload</b>	Voltage on secondary (load)
<b>Id</b>	Current in primary
<b>Is</b>	Current in secondary
<b>η</b>	Transformer output (typical 0.9) if resistive load $\cos \varphi=1$

<b>FIRING MODE</b>	ZC, PA, BF (bF.Cy≥ 2)
<b>HB DIAGNOSTICS AVAILABLE</b>	Partial and total load break
<b>Fuse</b>	Ultra-rapid fuse only required for controls with option Fuse = 0
<b>GG fuse</b>	See Fuse sections

(\*) = Connection only required with Vload input option (control option = 3)

### 3.6.3. Connection example for single-phase Thyritop 600 (1PH) control option 4 for single-phase load with transformer

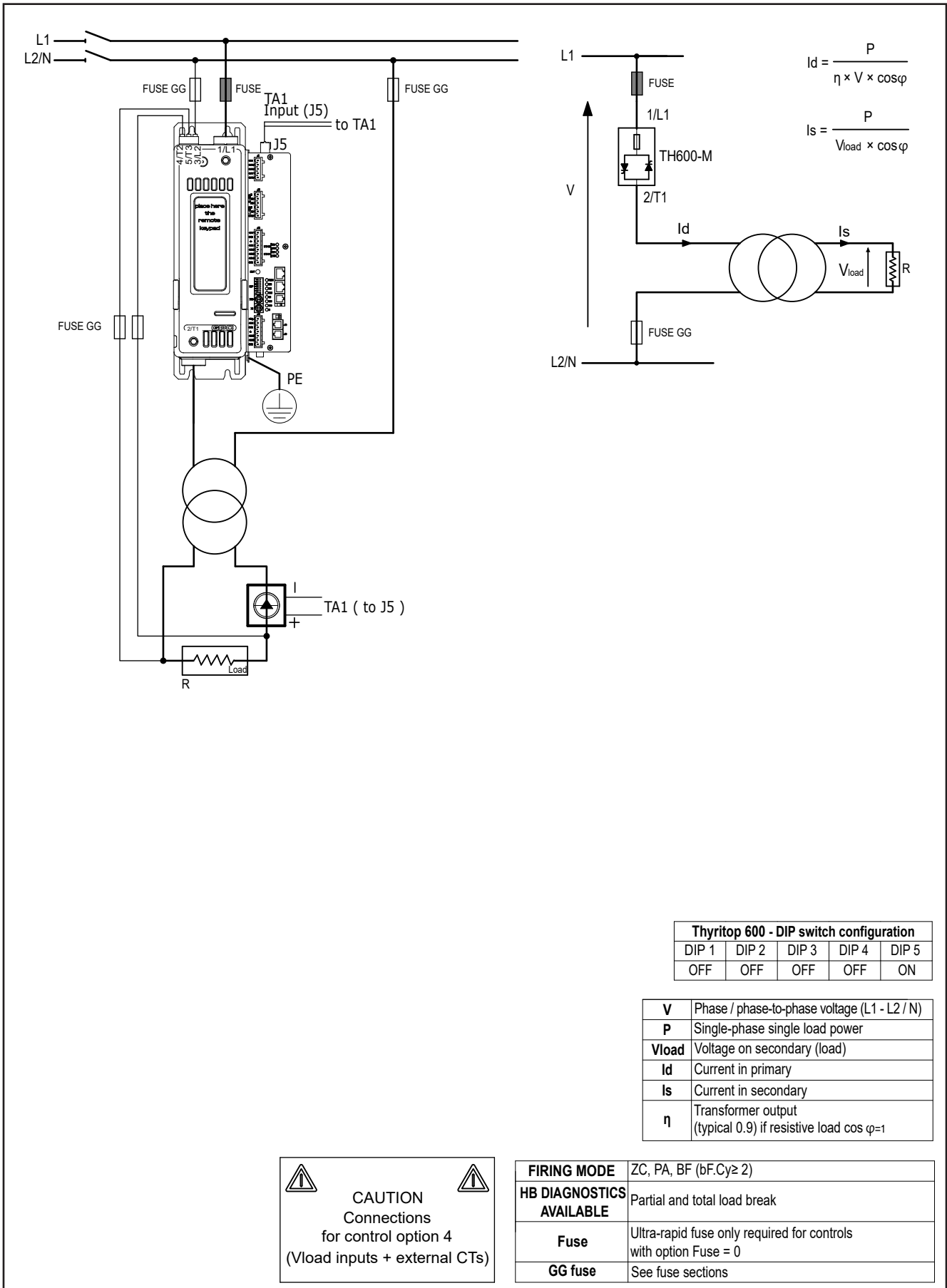

### 3.6.4. Connection example for two-phase Thyritop 600 (2PH) for 2 independent single-phase loads

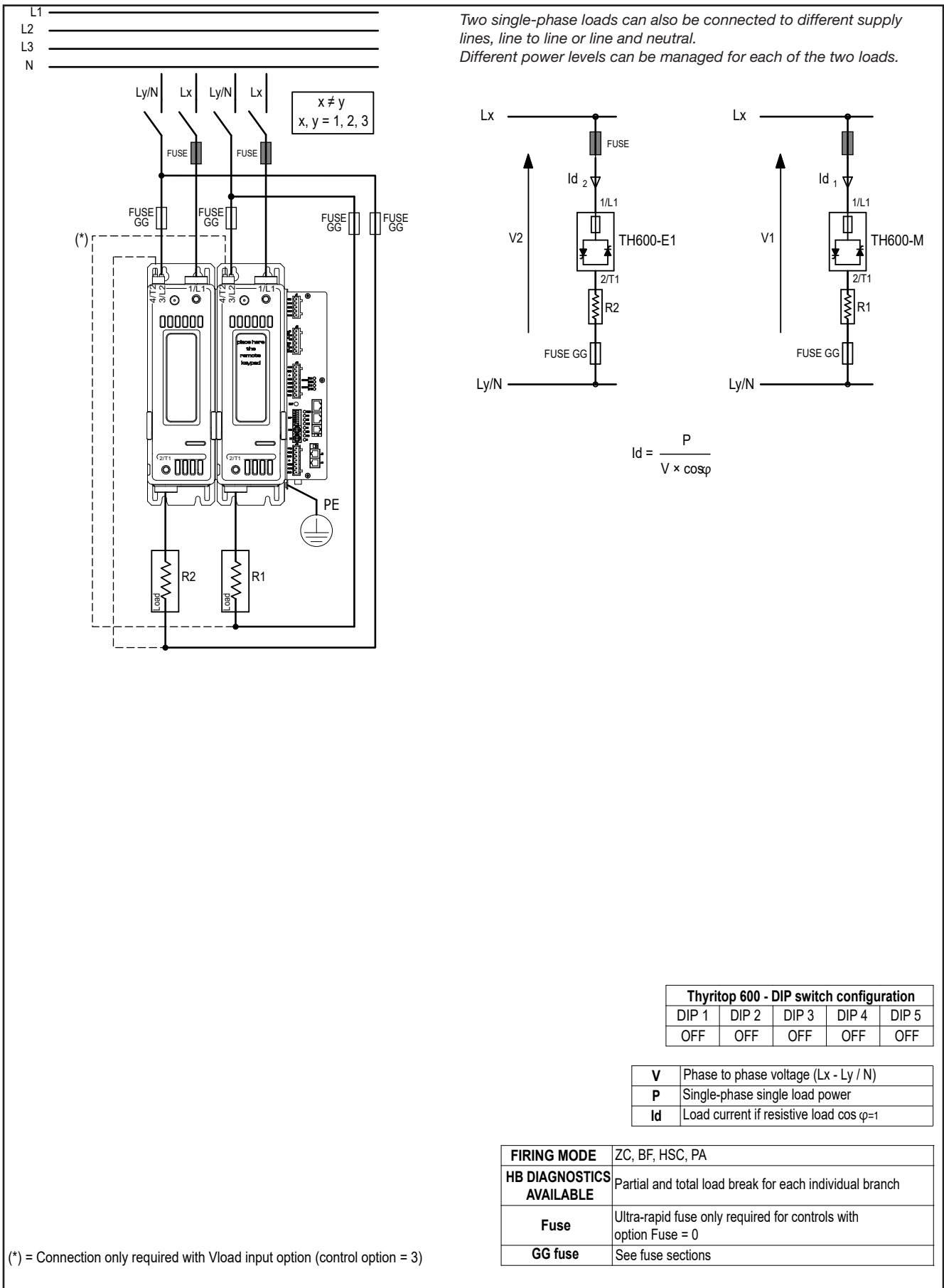

### 3.6.5. Connection example for two-phase Thyritop 600 (2PH) for a three-phase star load without neutral

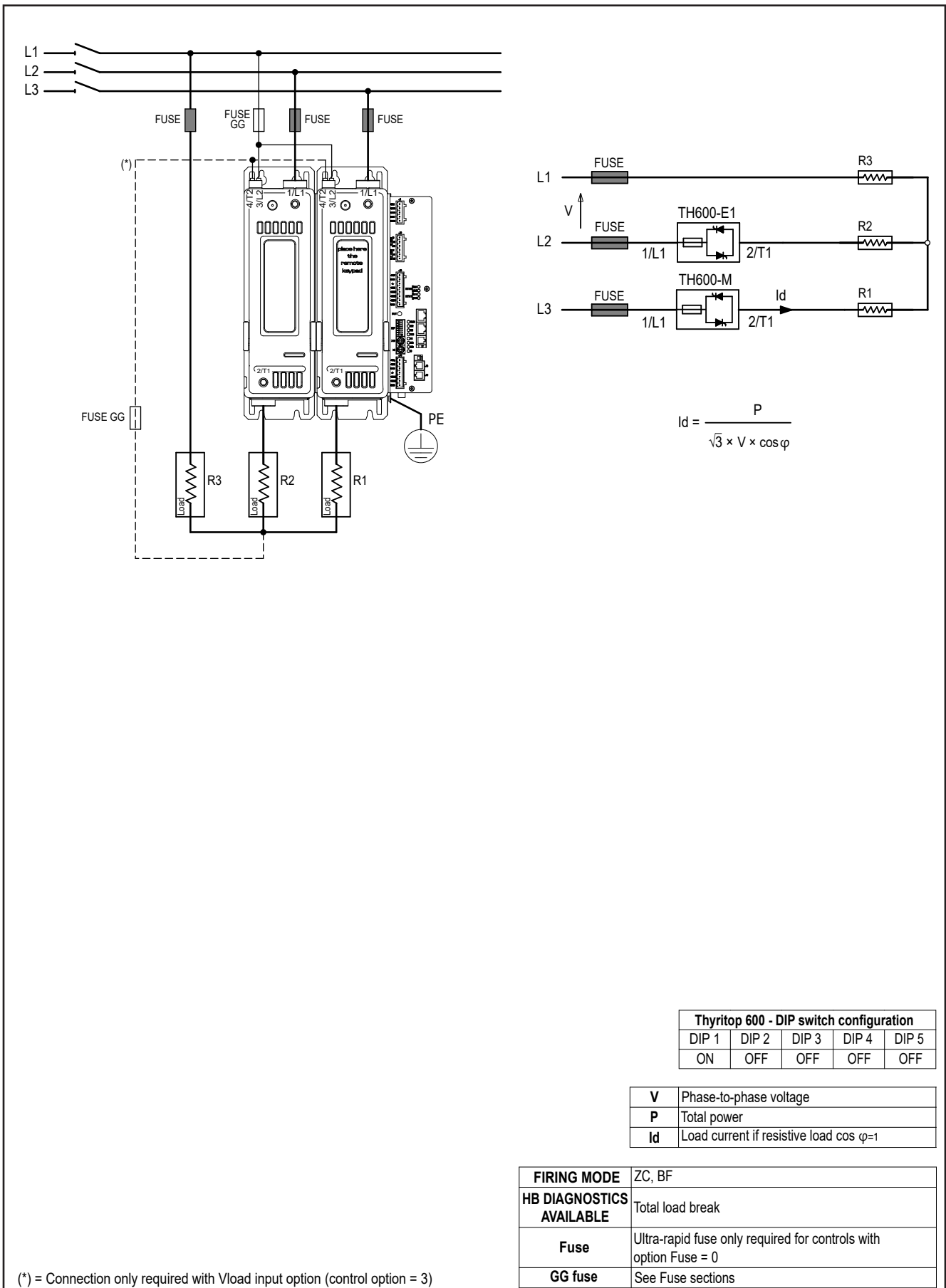

### 3.6.6. Connection example for two-phase Thyritop 600 (2PH) for a three-phase star load without neutral with transformer

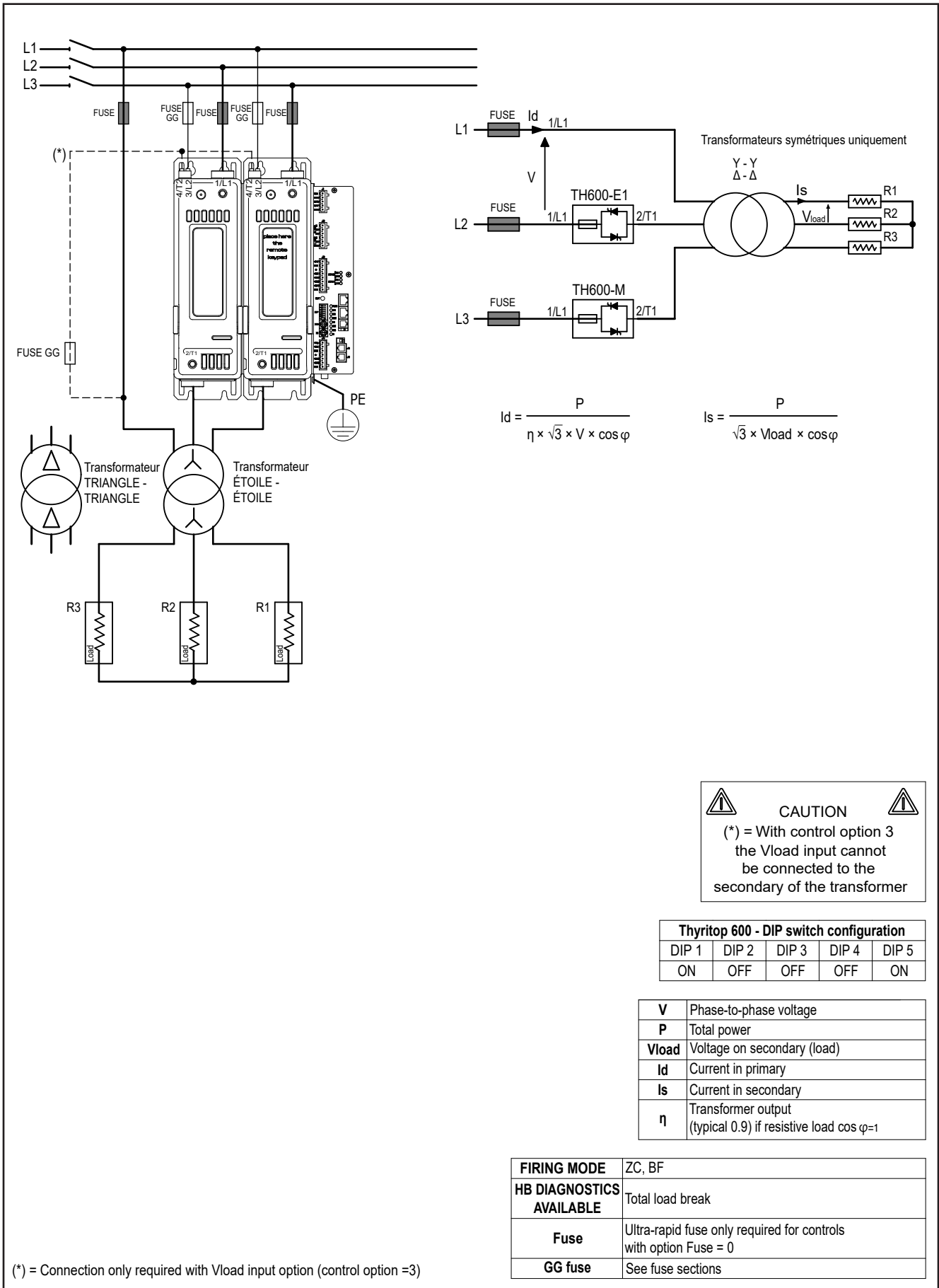

### 3.6.7. Connection example for two-phase Thyritop 600 (2PH) control option 4 for a three-phase star load without neutral with transformer

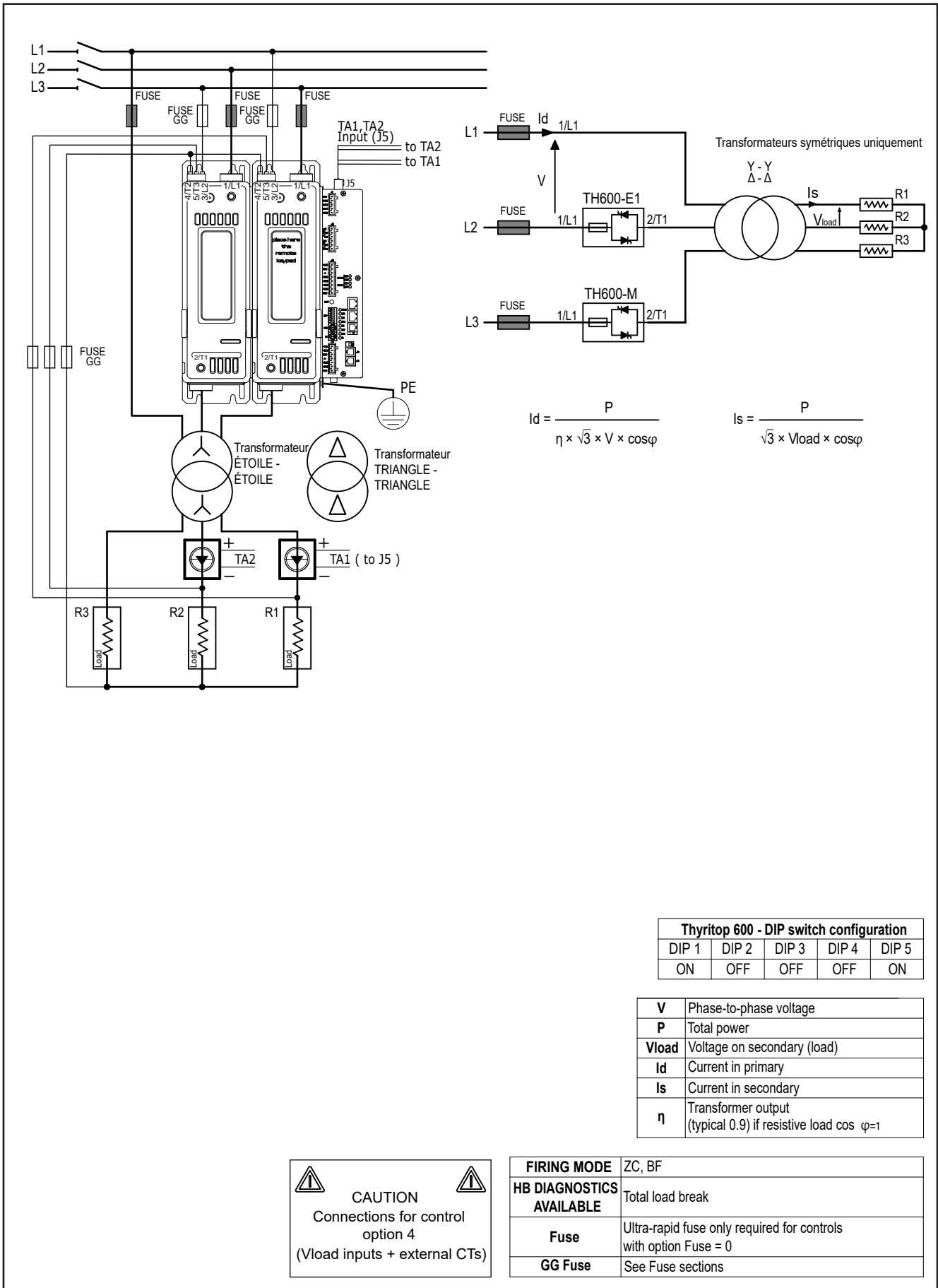

### 3.6.8. Connection example for two-phase Thyritop 600 (2PH) for a three-phase closed delta load

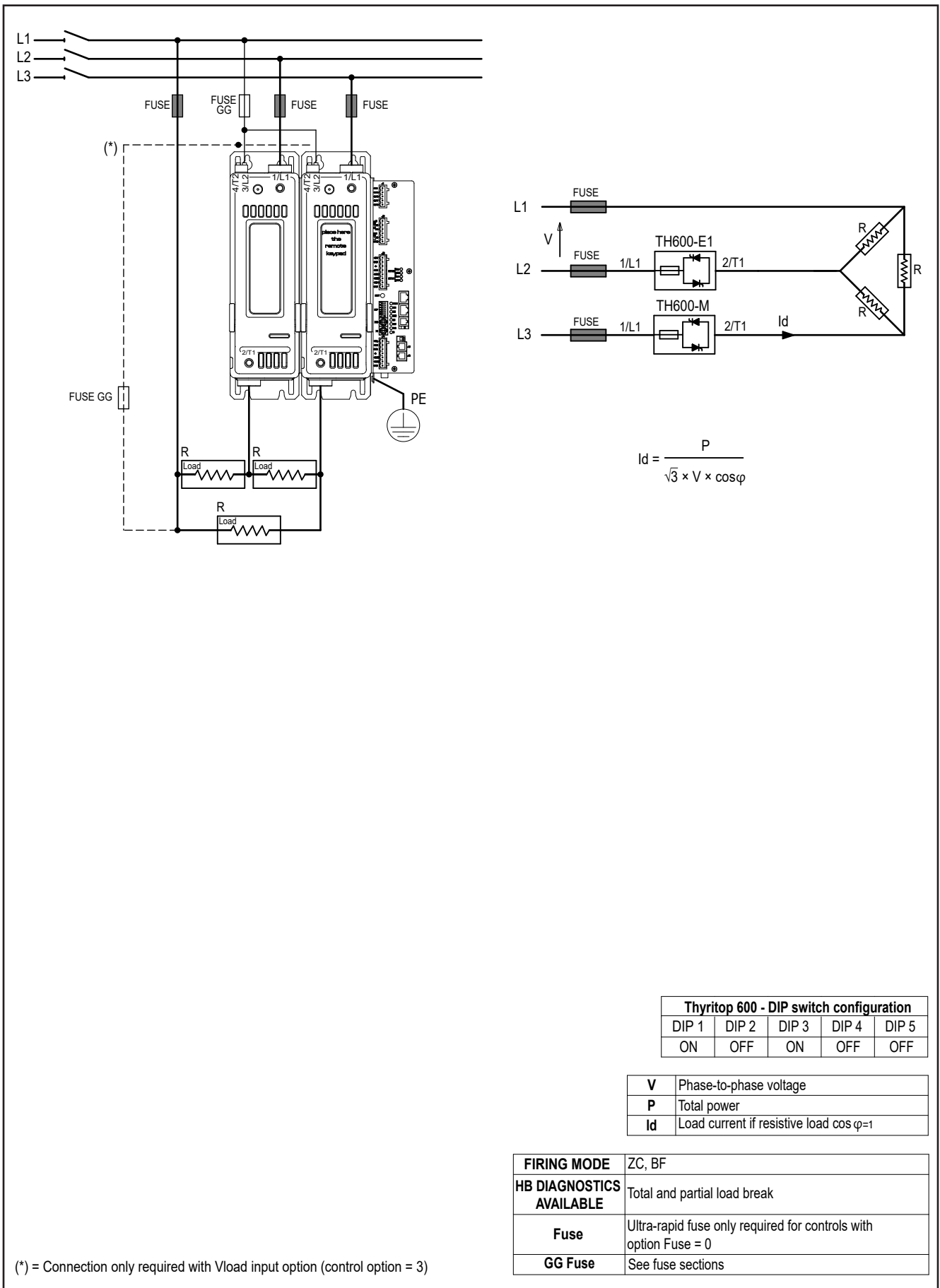

### 3.6.9. Connection example for two-phase Thyritop 600 (2PH) for a three-phase closed delta load with transformer

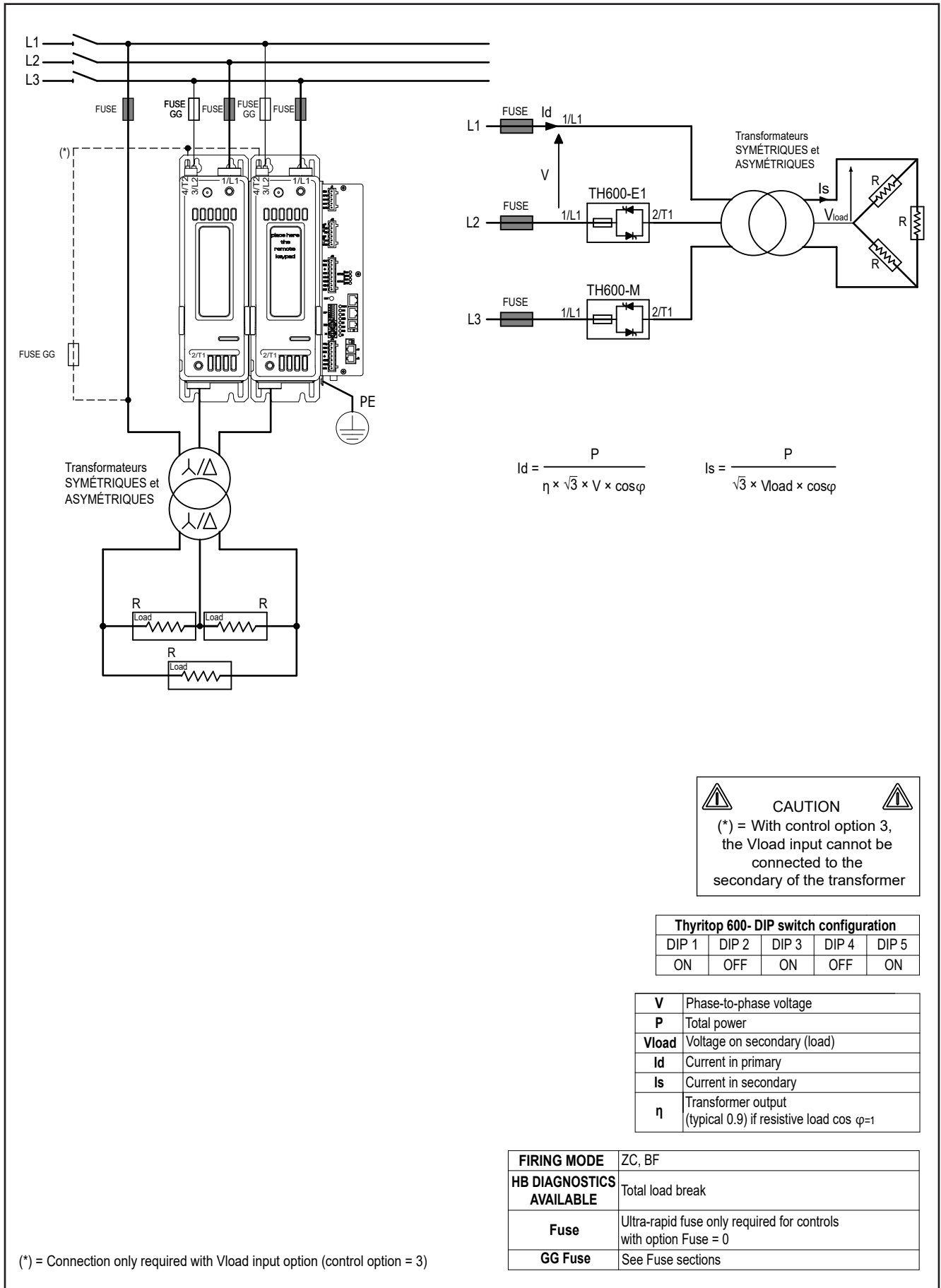



### 3.6.10. Connection example for two-phase Thyritop 600 (2PH) control option 4 for a closed delta load with transformer

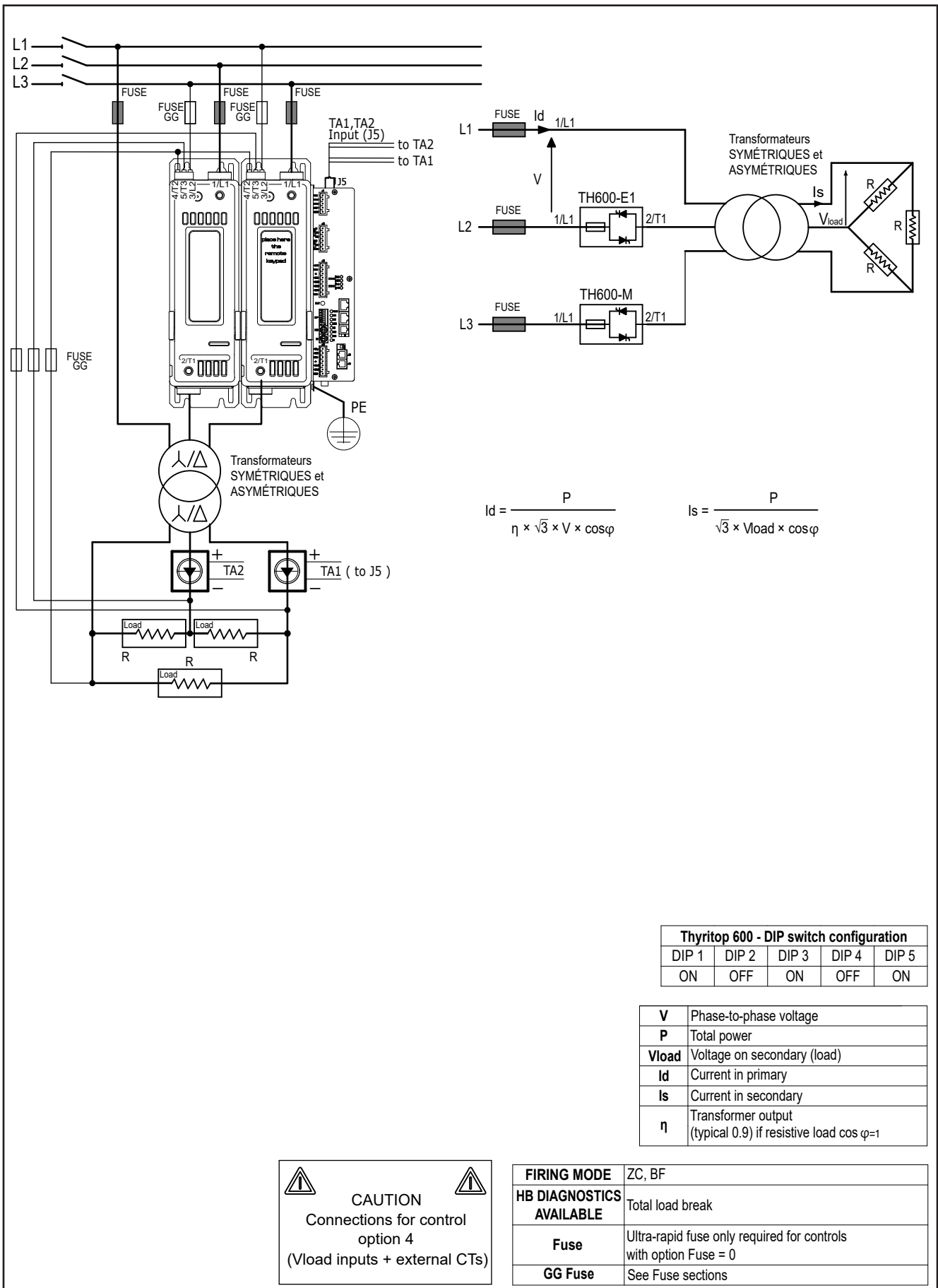

### 3.6.11. Connection example for three-phase Thyritop 600 (3PH) for 3 independent single-phase loads

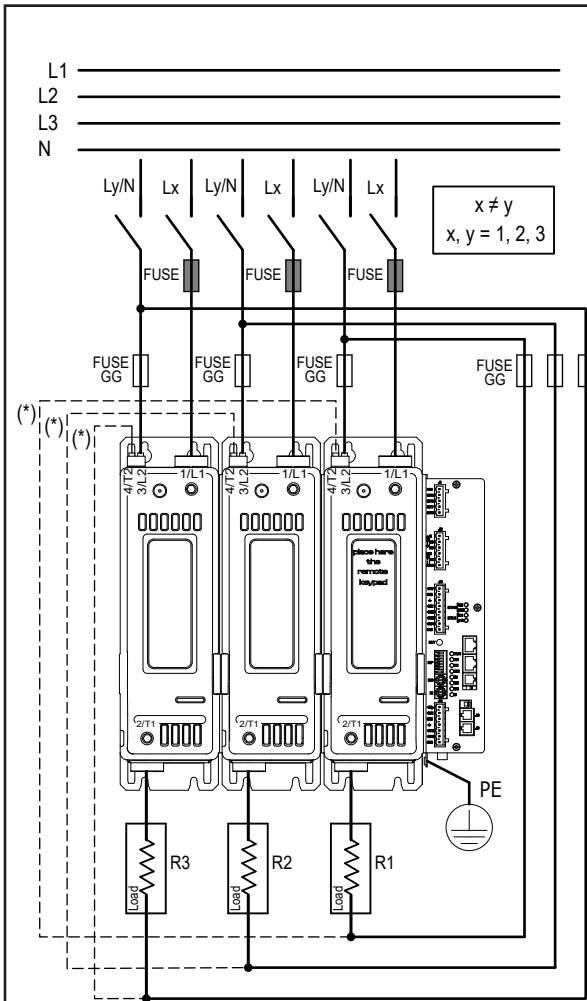

Two single-phase loads can also be connected to different supply lines, line to line or line and neutral.  
Different power levels can be managed for each of the two loads.

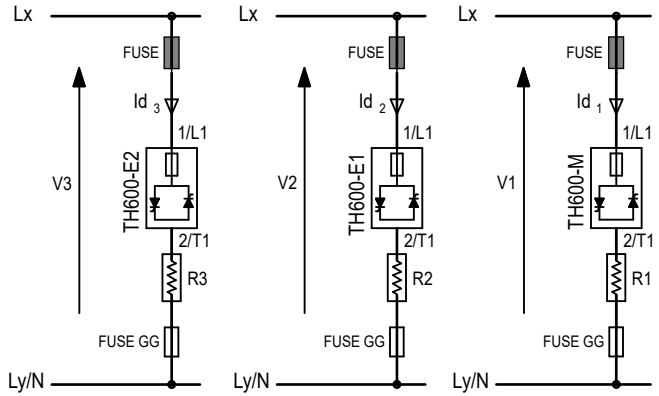

$$I_d = \frac{P}{V \times \cos\phi}$$

Thyritop 600 - DIP switch configuration				
DIP 1	DIP 2	DIP 3	DIP 4	DIP 5
OFF	OFF	OFF	OFF	OFF

<b>V</b>	Phase / phase-to-phase voltage (L1 - L2 / N)
<b>P</b>	Single-phase single load power
<b>Id</b>	Load current if resistive load $\cos\phi=1$

<b>FIRING MODE</b>	ZC, BF, HSC, PA
<b>HB DIAGNOSTICS AVAILABLE</b>	Partial and total load break for each individual branch
<b>Fuse</b>	Ultra-rapid fuse only required for controls with option Fuse = 0
<b>GG Fuse</b>	See Fuse sections

(\*) = Connection only required with Vload input option (control option = 3)

### 3.6.12. Connection example for three-phase Thyritop 600 (3PH) for a three-phase star load with neutral

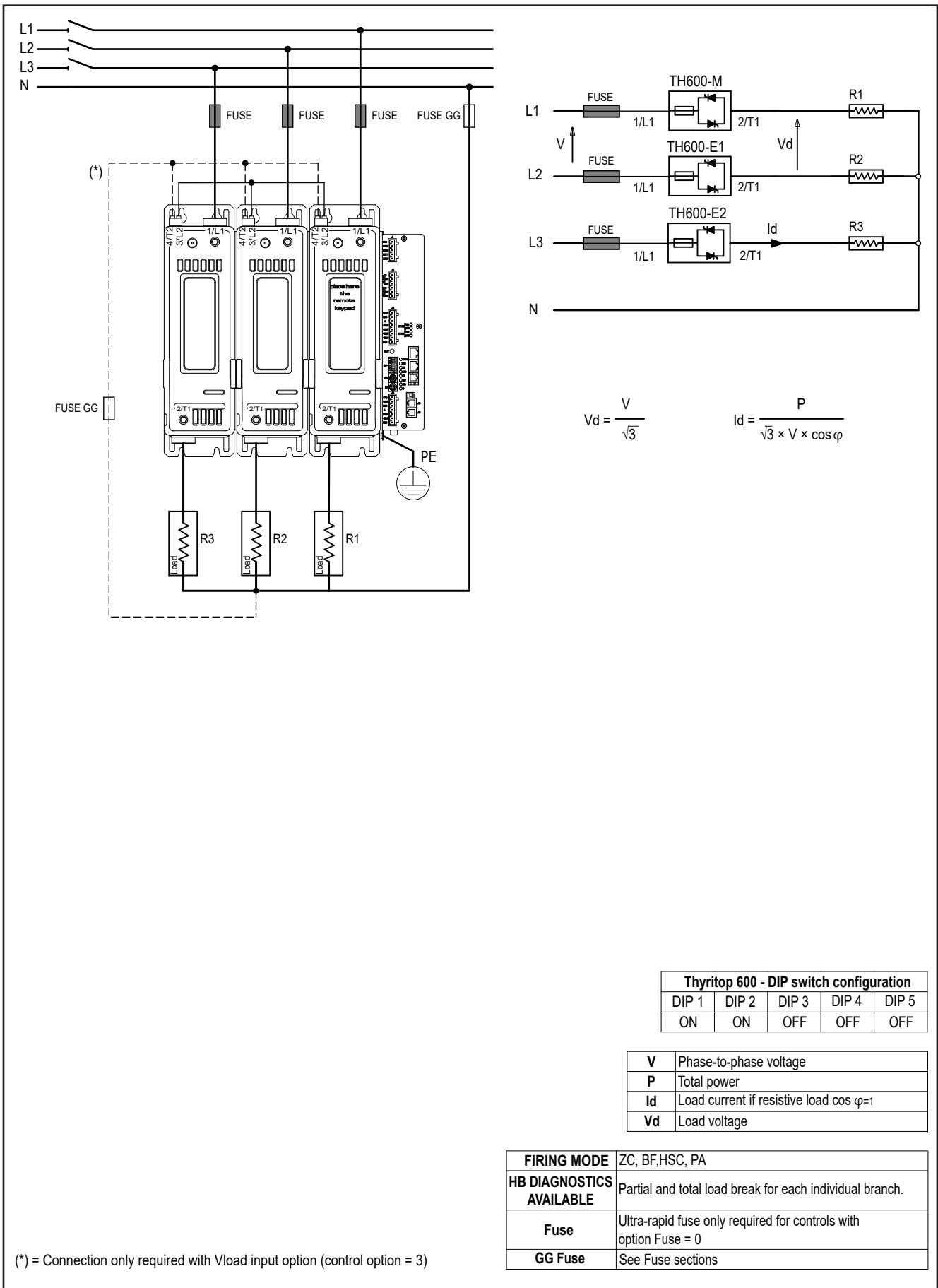

### 3.6.13. Connection example for three-phase Thyritop 600 (3PH) for a three-phase star load without neutral

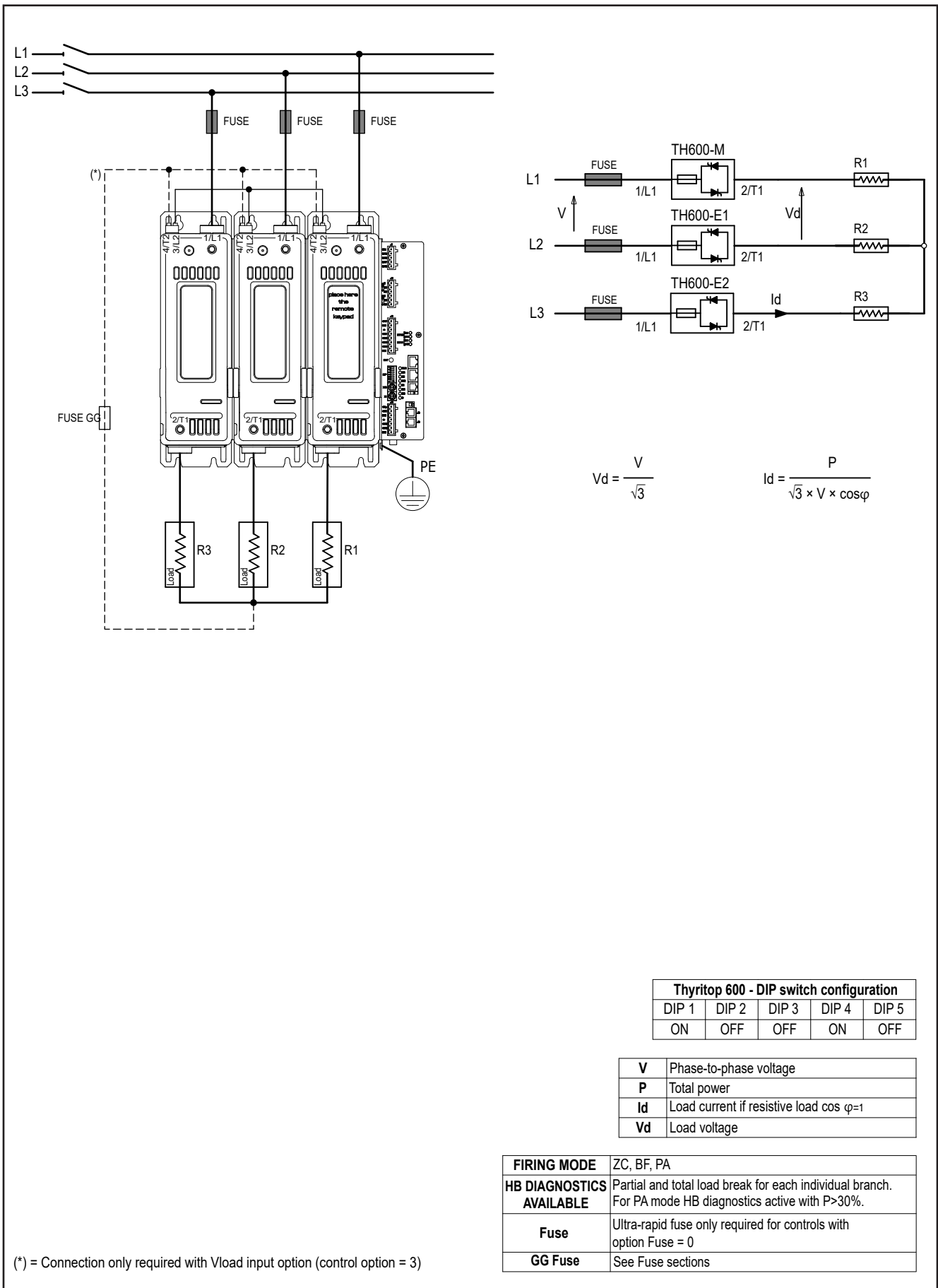

**3.6.14. Connection example for three-phase Thyritop 600 (3PH) for a three-phase star load without neutral with transformer**

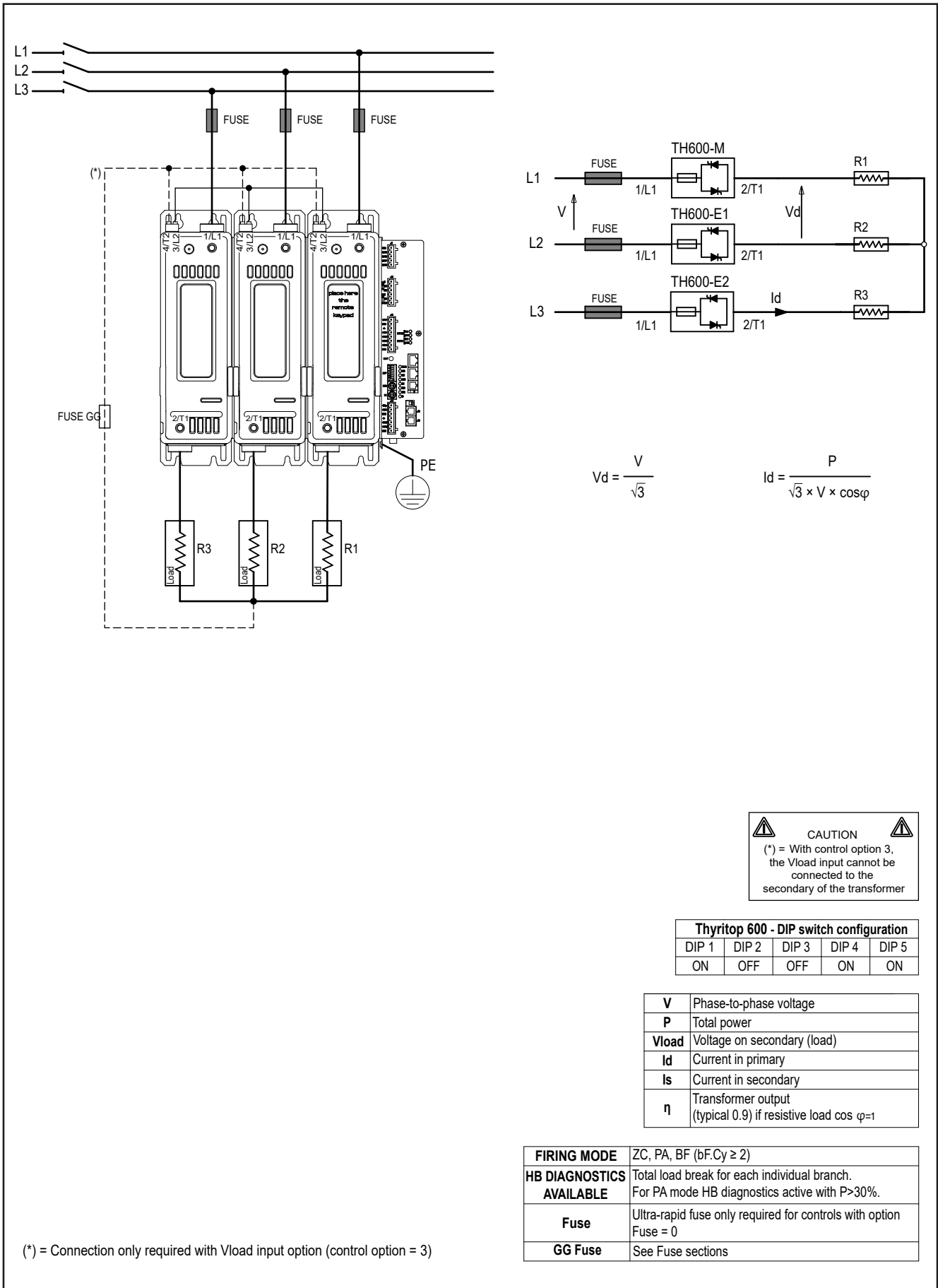

### 3.6.15. Connection example for three-phase Thyritop 600 (3PH) control option 4 for a three-phase star load without neutral with transformer

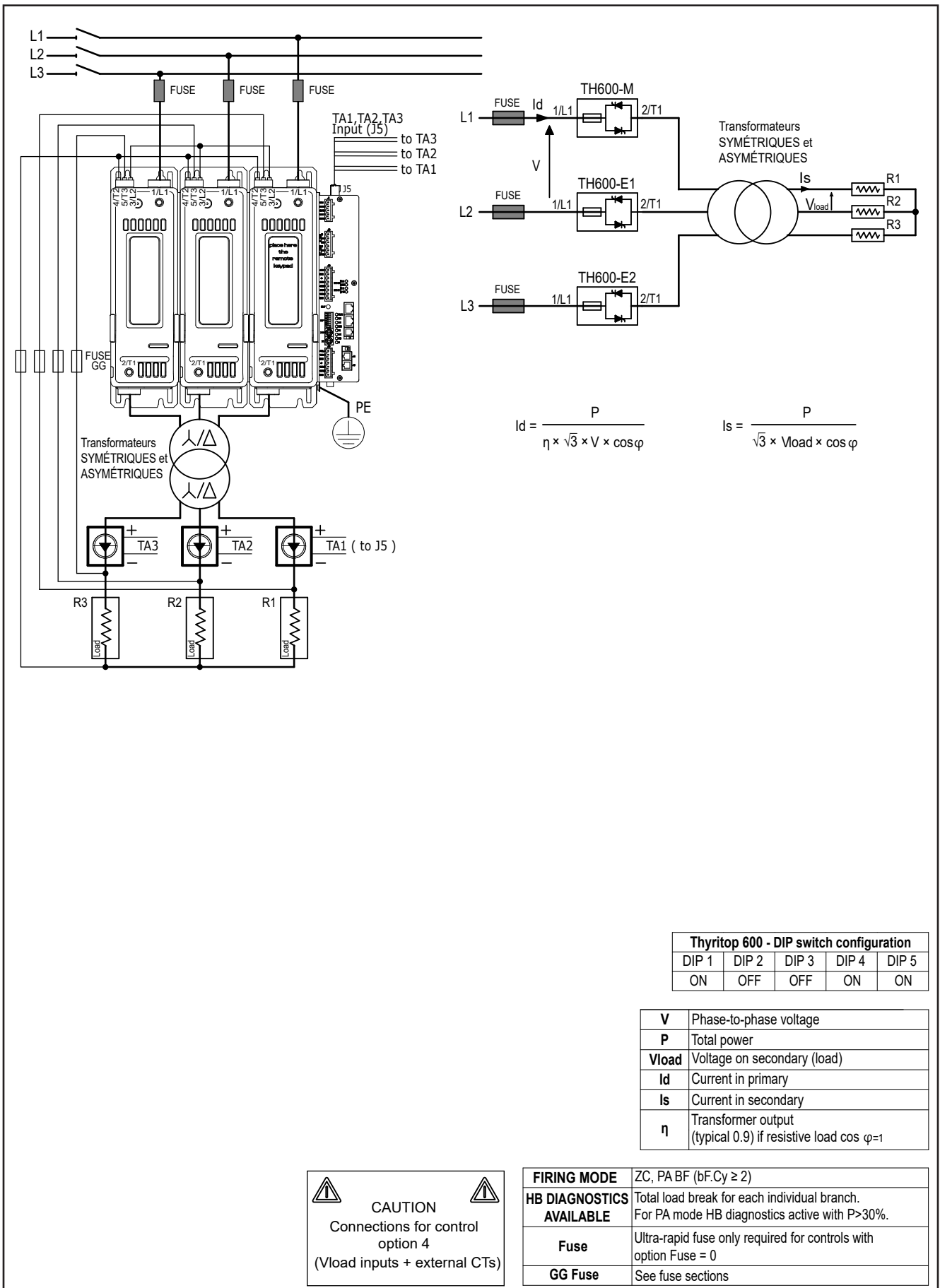

**3.6.16. Connection example for three-phase Thyritop 600 (3PH) for three-phase closed delta load**

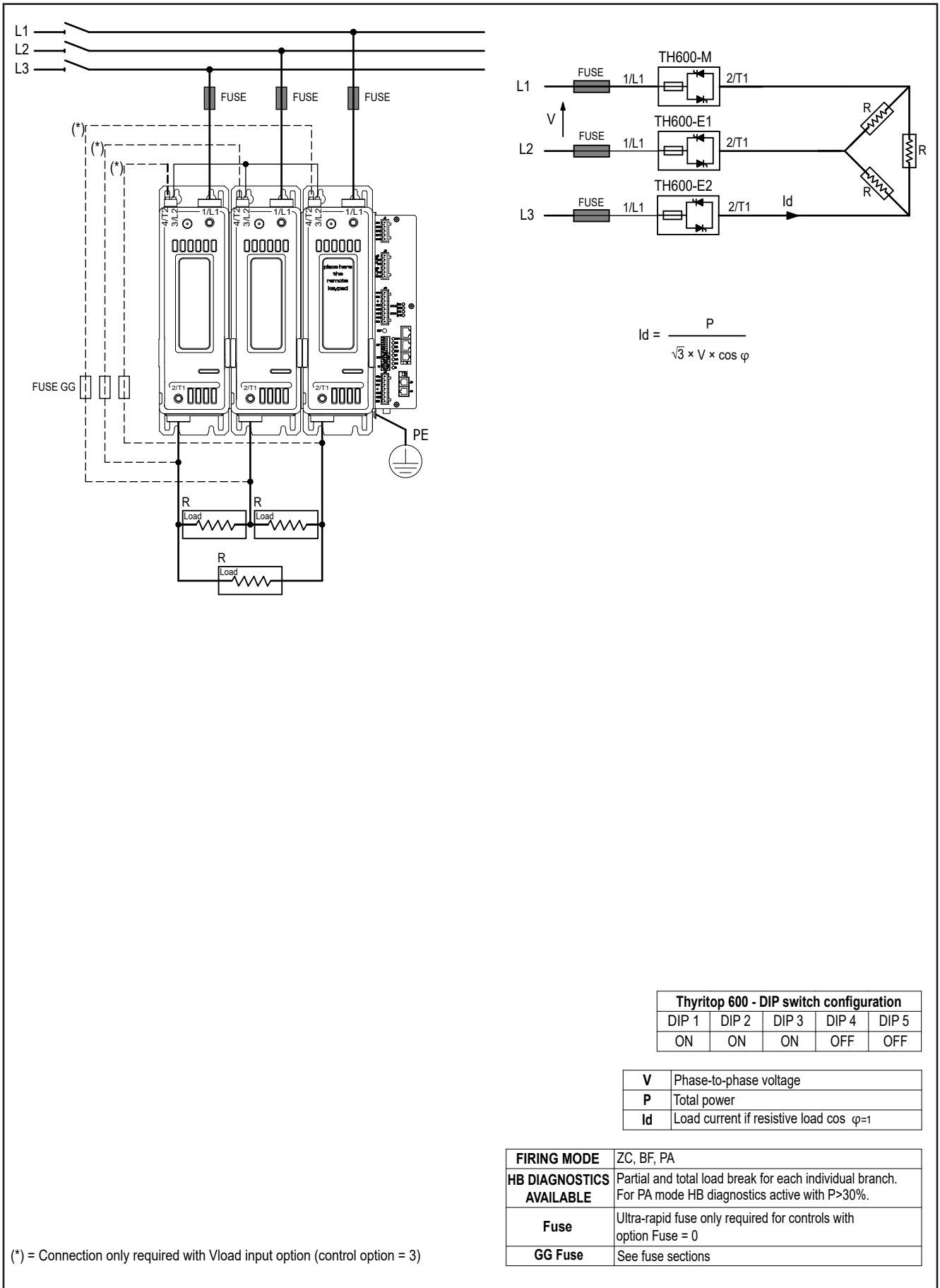

### 3.6.17. Connection example for three-phase Thyritop 600 (3PH) for a three-phase closed delta load with transformer

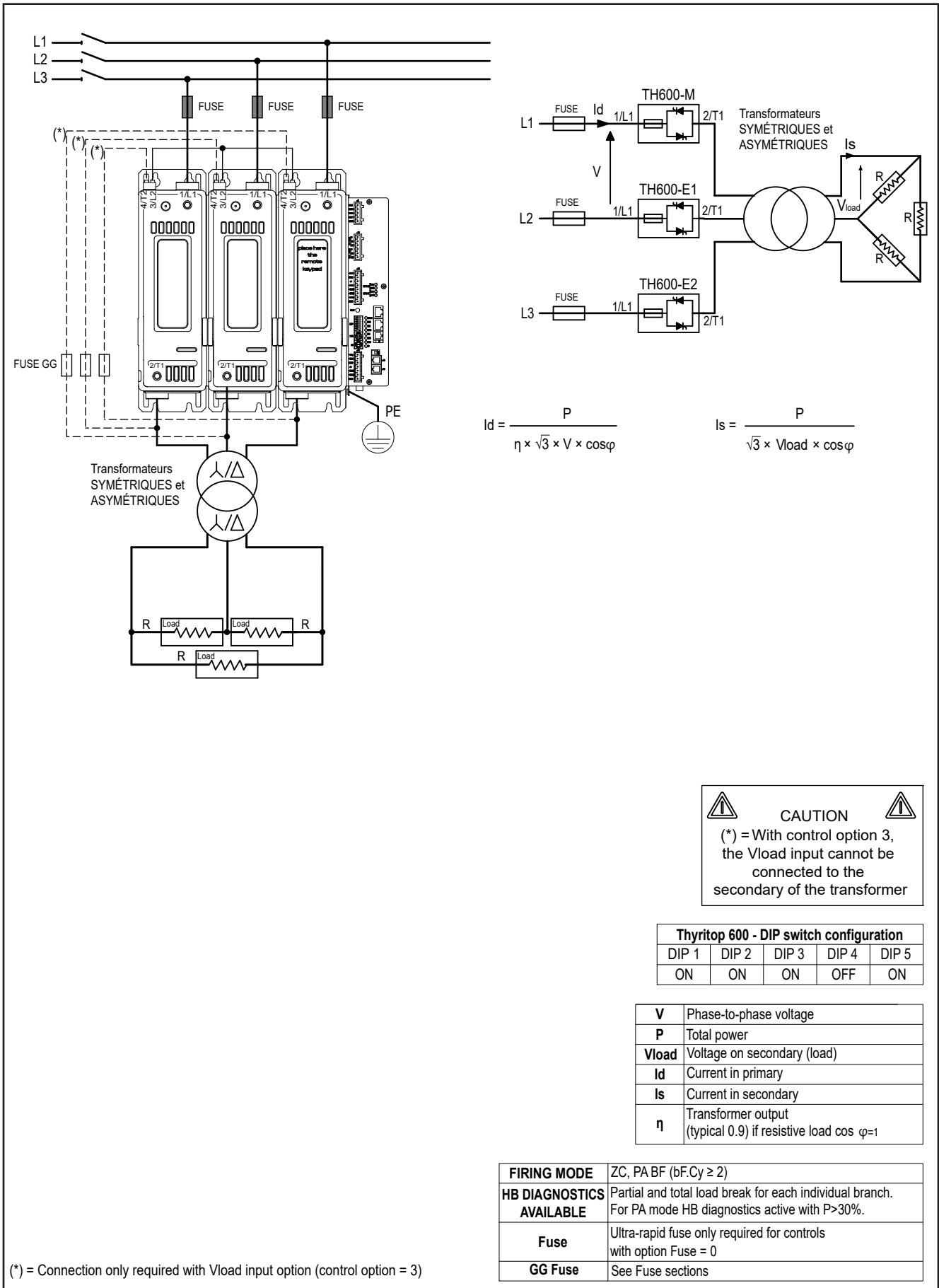



**3.6.18. Connection example for three-phase Thyritop 600 (3PH) control option 4 for three-phase closed delta load with transformer**

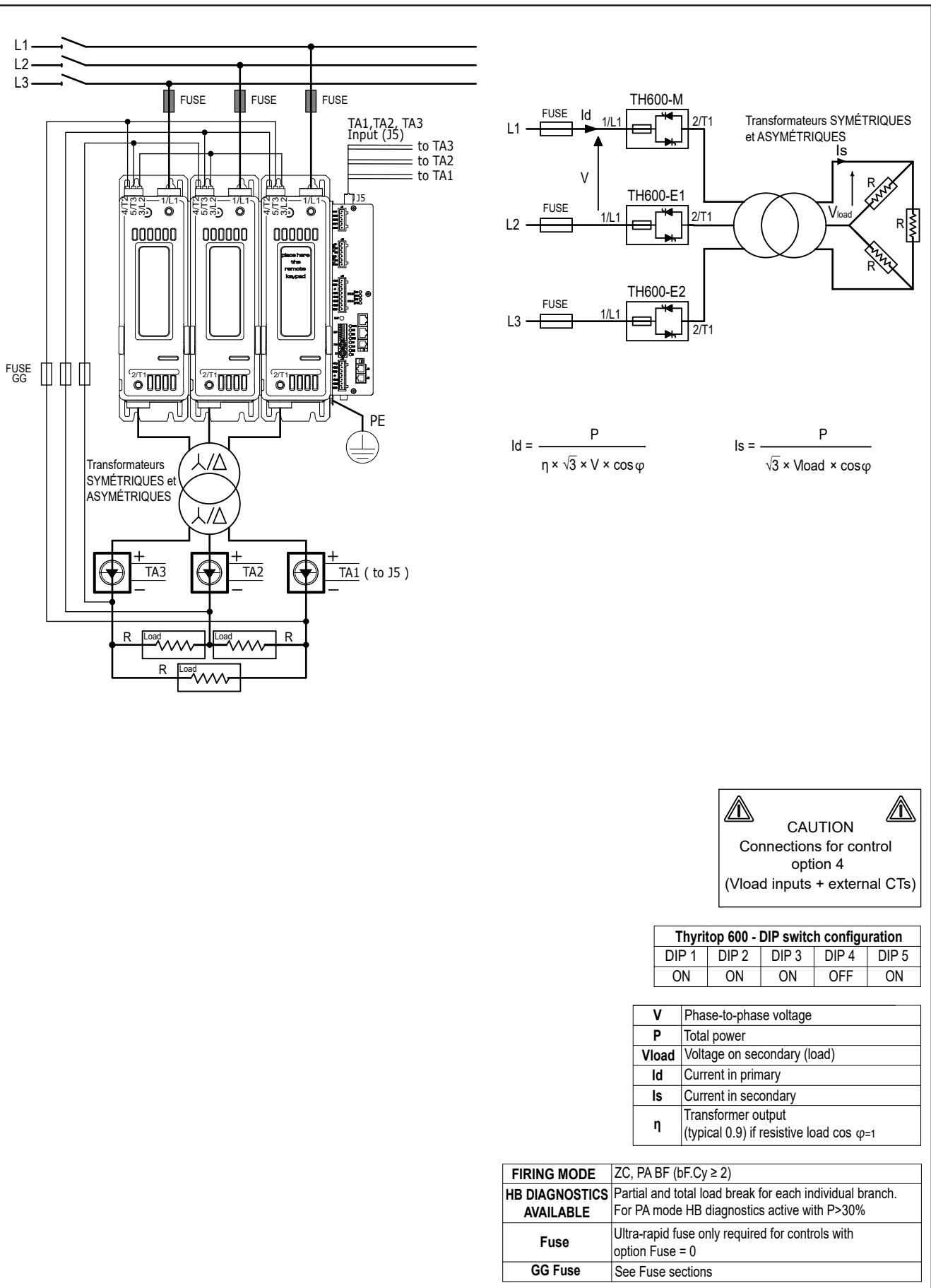

### 3.6.19. Connection example for three-phase Thyritop 600 (3PH) for three-phase open delta load

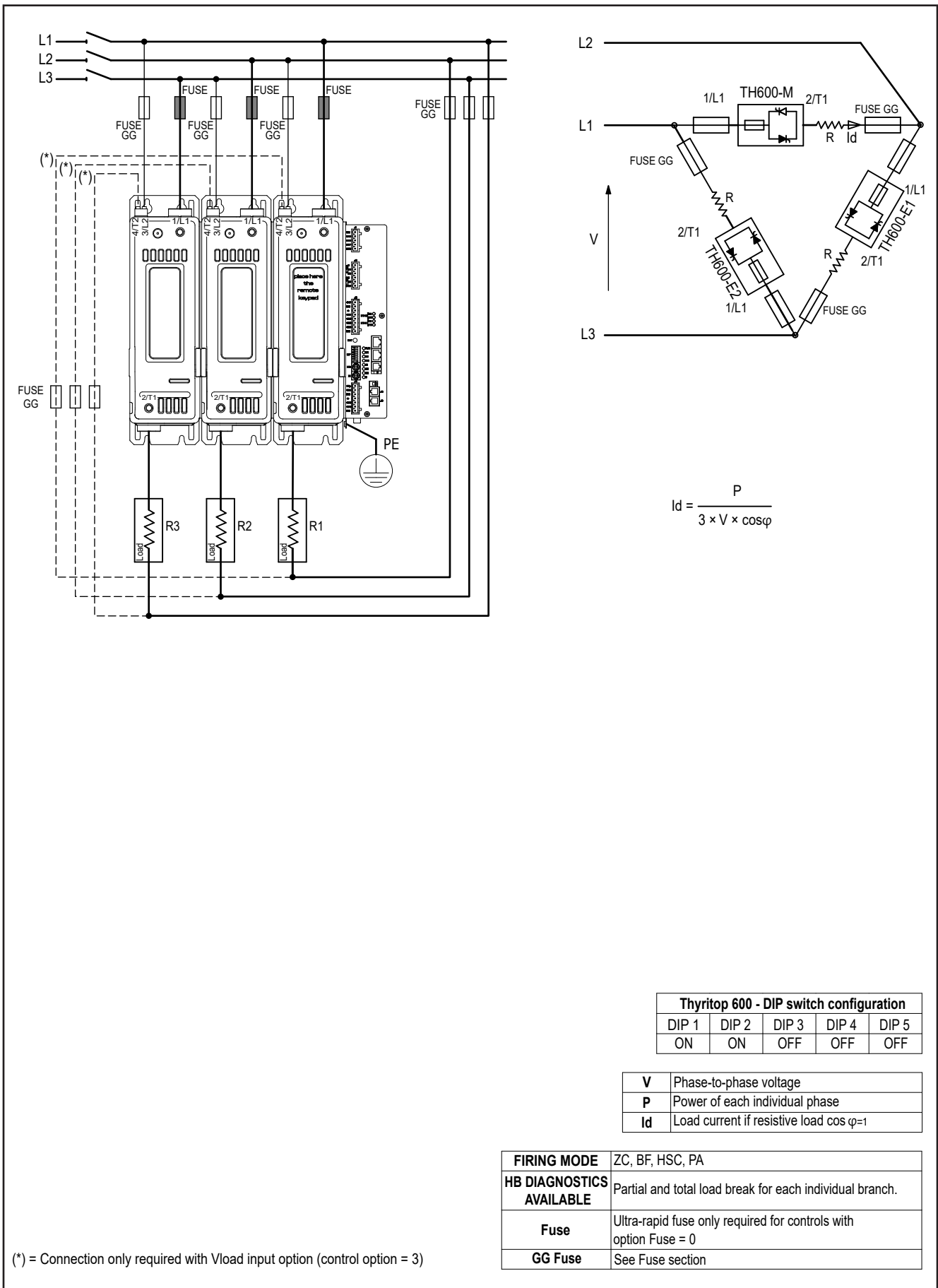

### 3.6.20. Connection example for three-phase Thyritop 600 (3PH) for 3 independent loads in open delta

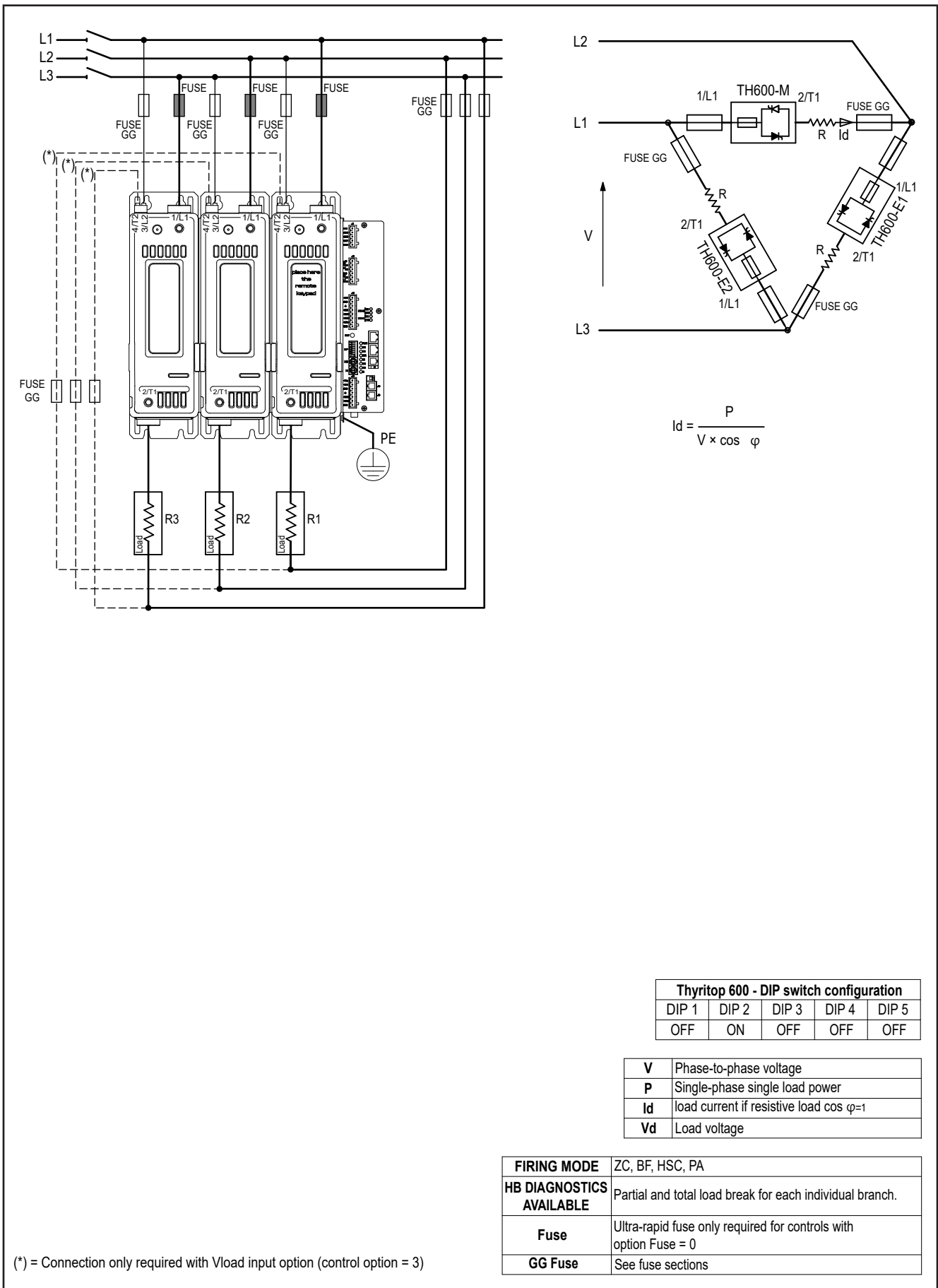

### 3.7. Connection examples - Power section for Thyritop 600 400 A...600 A

#### 3.7.1. Connection example for single-phase Thyritop 600 (1PH) for a single-phase load

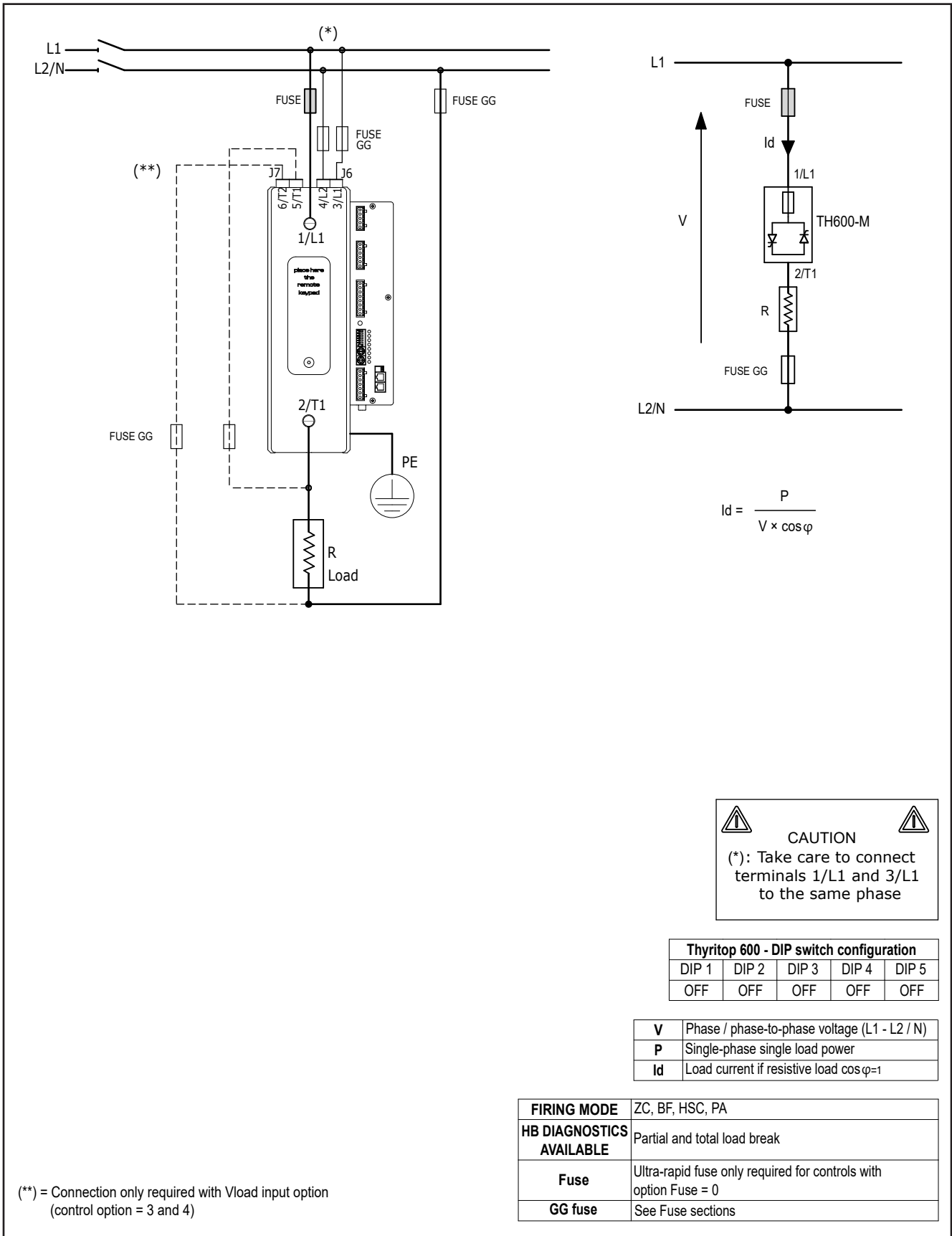

### 3.7.2. Connection example for single-phase Thyritop 600 (1PH) for a single-phase load with transformer

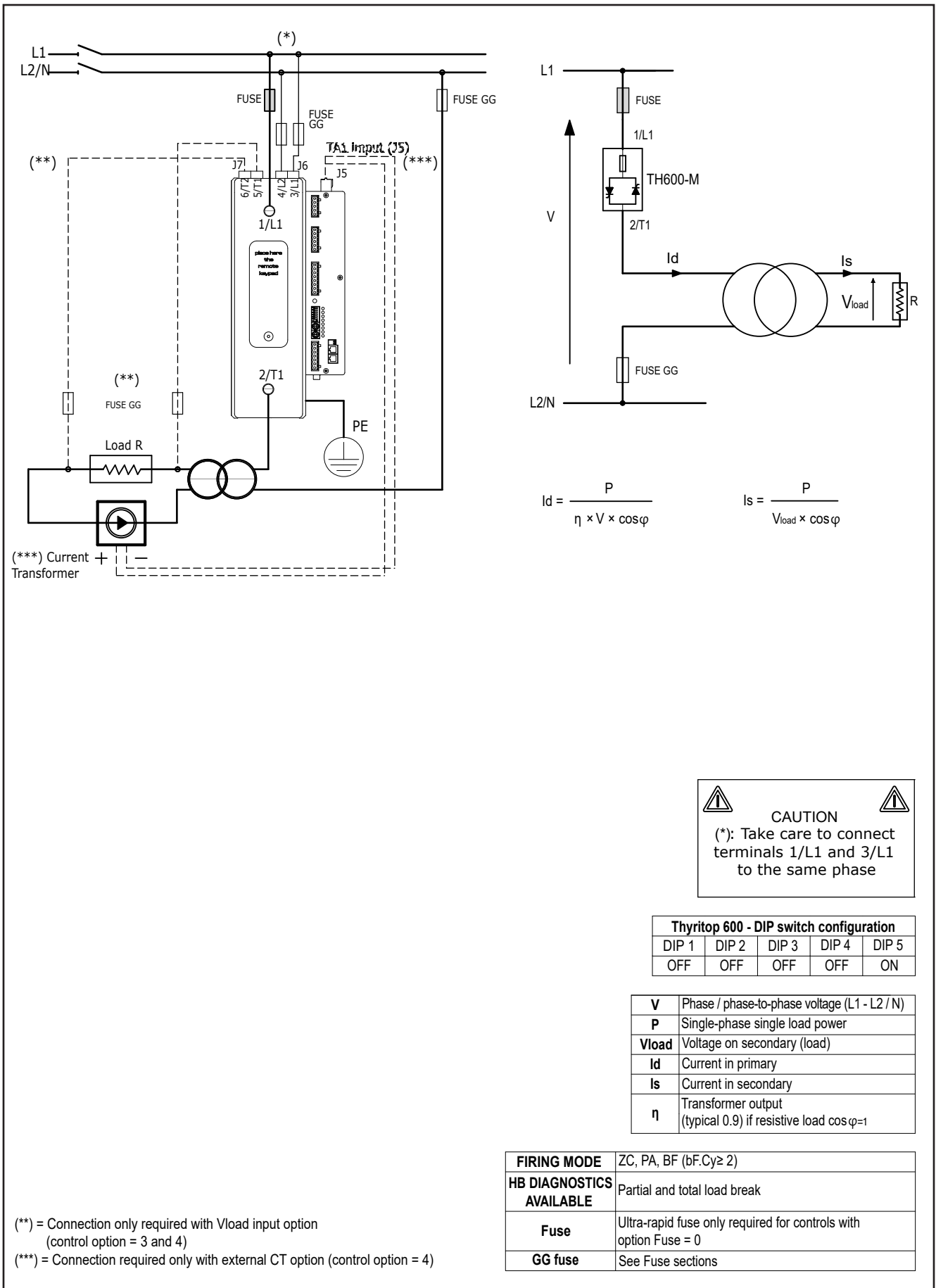

### 3.7.3. Connection example for two-phase Thyritop 600 (2PH) for 2 independent single-phase loads

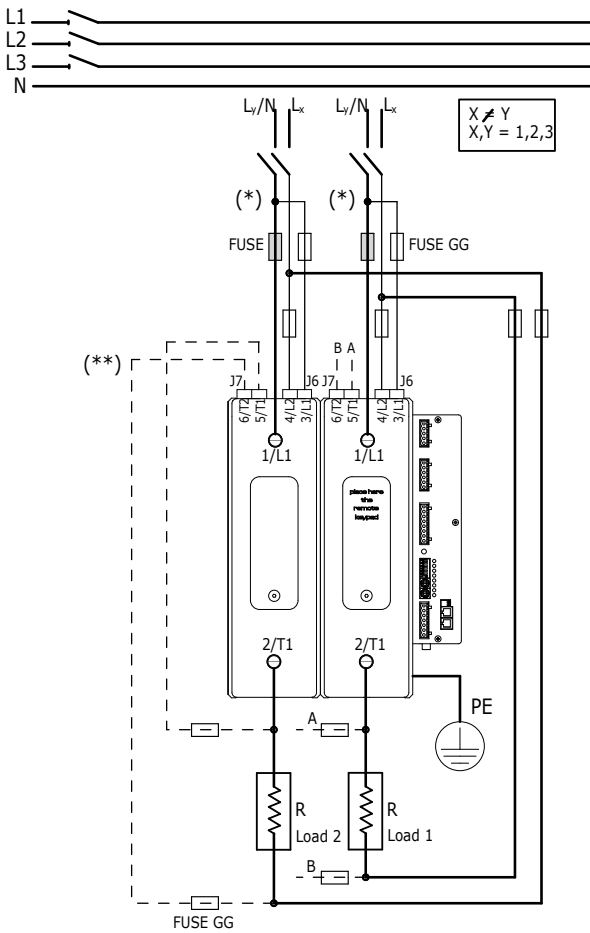

Two single-phase loads can also be connected to different supply lines, line to line or line and neutral. Different power levels can be managed for each of the two loads.

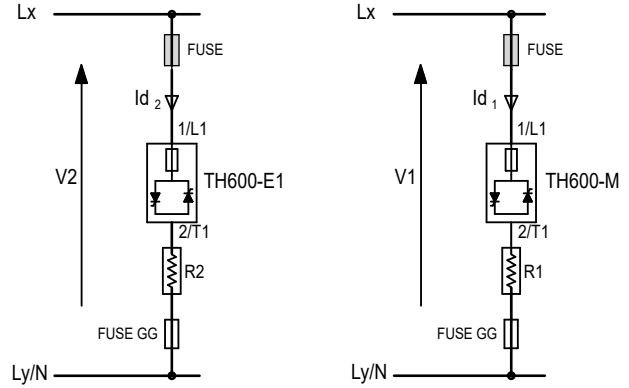

$$I_d = \frac{P}{V \times \cos \varphi}$$

**CAUTION**  
 (\*): Take care to connect terminals 1/L1 and 3/L1 to the same phase

Thyritop 600 - DIP switch configuration				
DIP 1	DIP 2	DIP 3	DIP 4	DIP 5
OFF	OFF	OFF	OFF	OFF

<b>V</b>	Phase / phase-to-phase voltage (Lx - Ly / N)
<b>P</b>	Single-phase single load power
<b>I<sub>d</sub></b>	load current if resistive load cos φ=1

<b>FIRING MODE</b>	ZC, BF, HSC, PA
<b>HB DIAGNOSTICS AVAILABLE</b>	Partial and total load break for each individual branch
<b>Fuse</b>	Ultra-rapid fuse only required for controls with option Fuse = 0
<b>GG fuse</b>	See fuse sections

(\*\*) = Connection only required with Vload input option (control option = 3 and 4)

### 3.7.4. Connection example for two-phase Thyritop 600 (2PH) for a three-phase star load without neutral

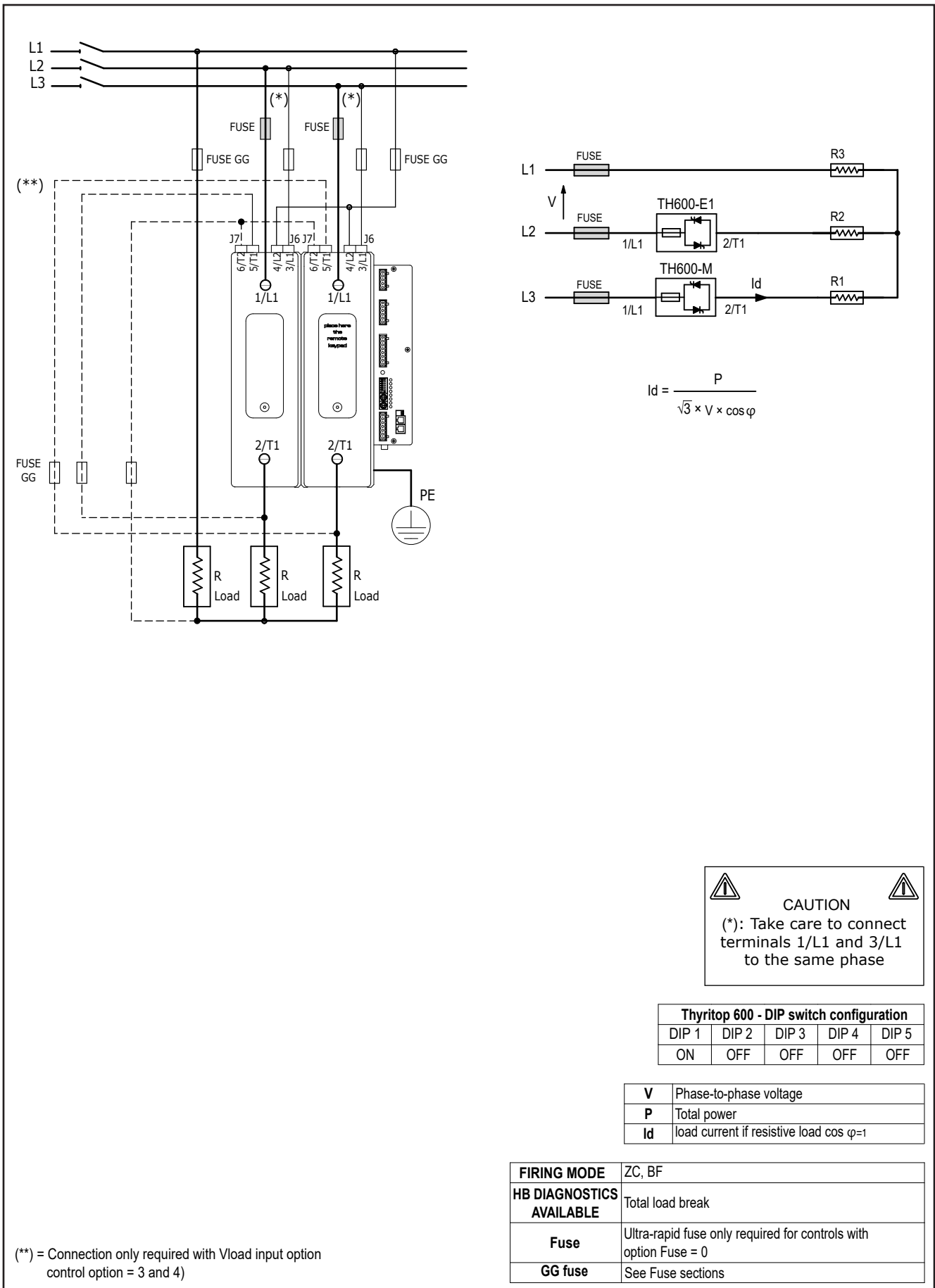

### 3.7.5. Connection example for two-phase Thyritop 600 (2PH) for a three-phase star load without neutral with transformer

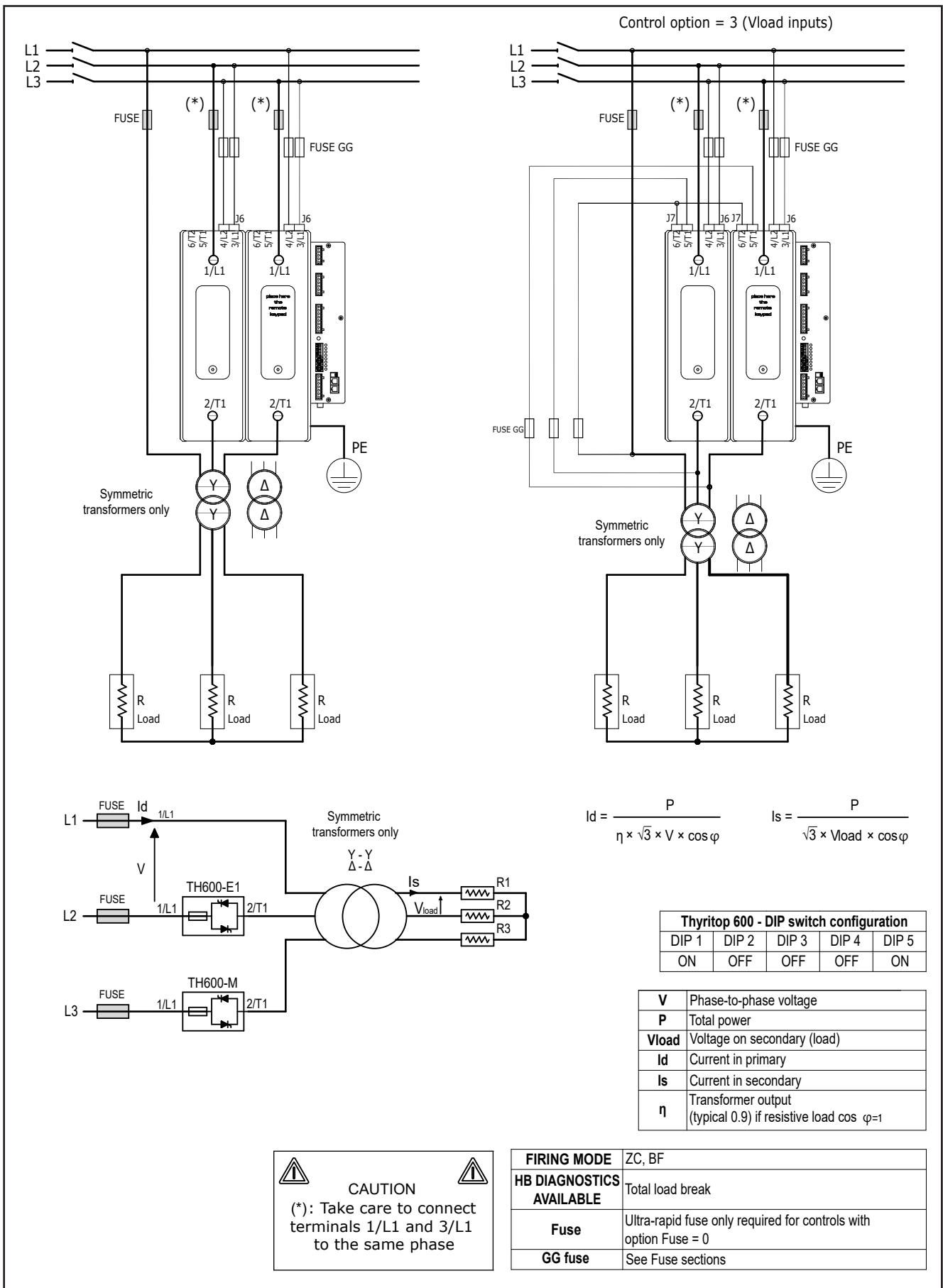



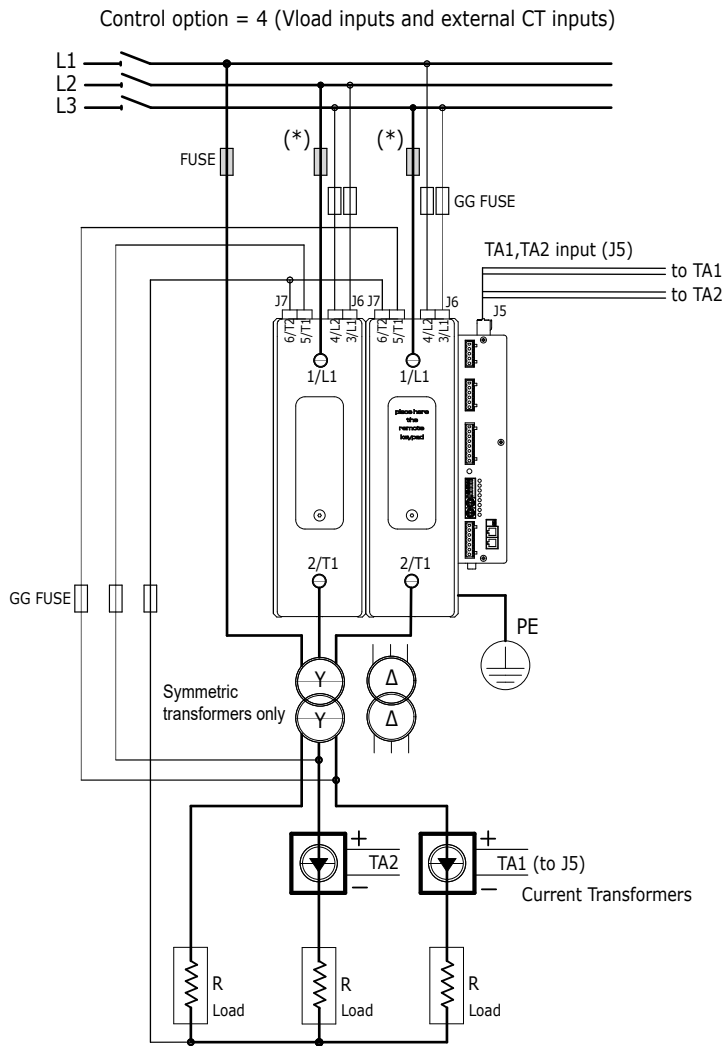

Thyritop 600 - DIP switch configuration				
DIP 1	DIP 2	DIP 3	DIP 4	DIP 5
ON	OFF	OFF	OFF	ON

<b>V</b>	Phase-to-phase voltage
<b>P</b>	Total power
<b>Vload</b>	Voltage on secondary (load)
<b>Id</b>	Current in primary
<b>Is</b>	Current in secondary
<b>η</b>	Transformer output (typical 0.9) if resistive load $\cos \varphi=1$

**CAUTION**

(\*): Take care to connect terminals 1/L1 and 3/L1 to the same phase

<b>FIRING MODE</b>	ZC, BF
<b>HB DIAGNOSTICS AVAILABLE</b>	Total load break
<b>Fuse</b>	Ultra-rapid fuse only required for controls with option Fuse = 0
<b>GG fuse</b>	See Fuse sections

### 3.7.6. Connection example for two-phase Thyritop 600 (2PH) for a three-phase closed delta load

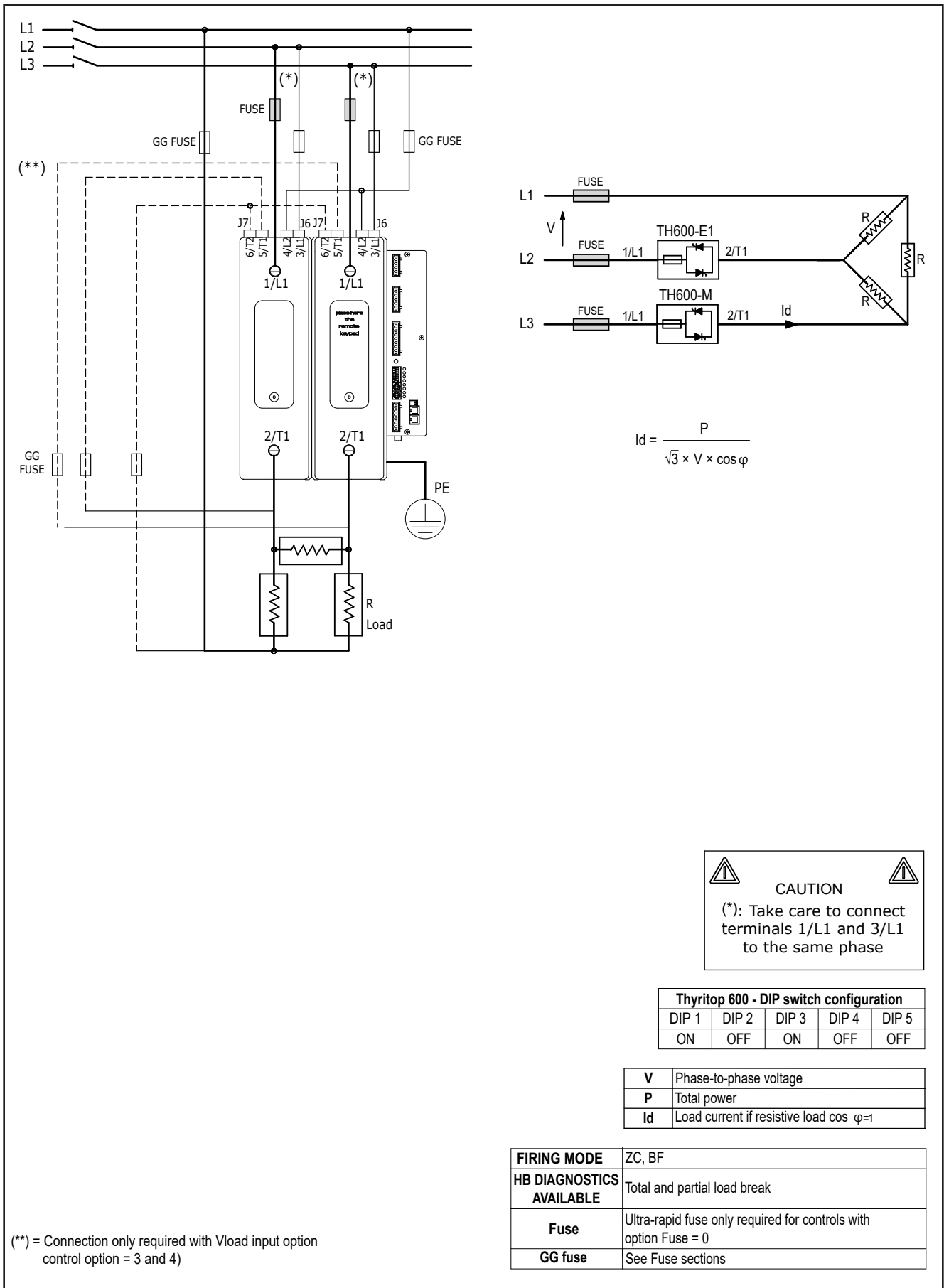

### 3.7.7. Connection example for two-phase Thyritop 600 (2PH) for a three-phase closed delta load with transformer

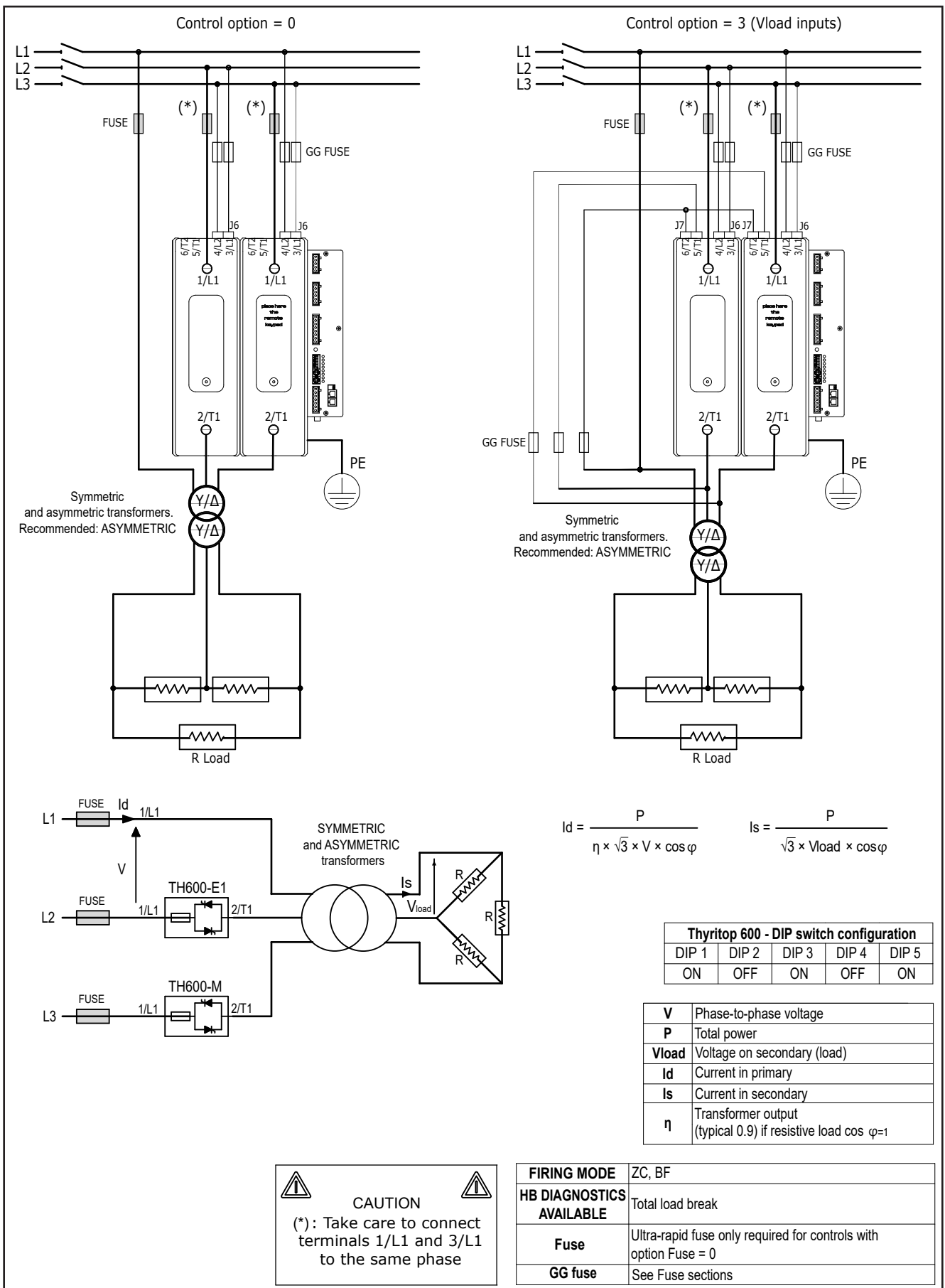

Control option = 4 (Vload inputs and external CT inputs)

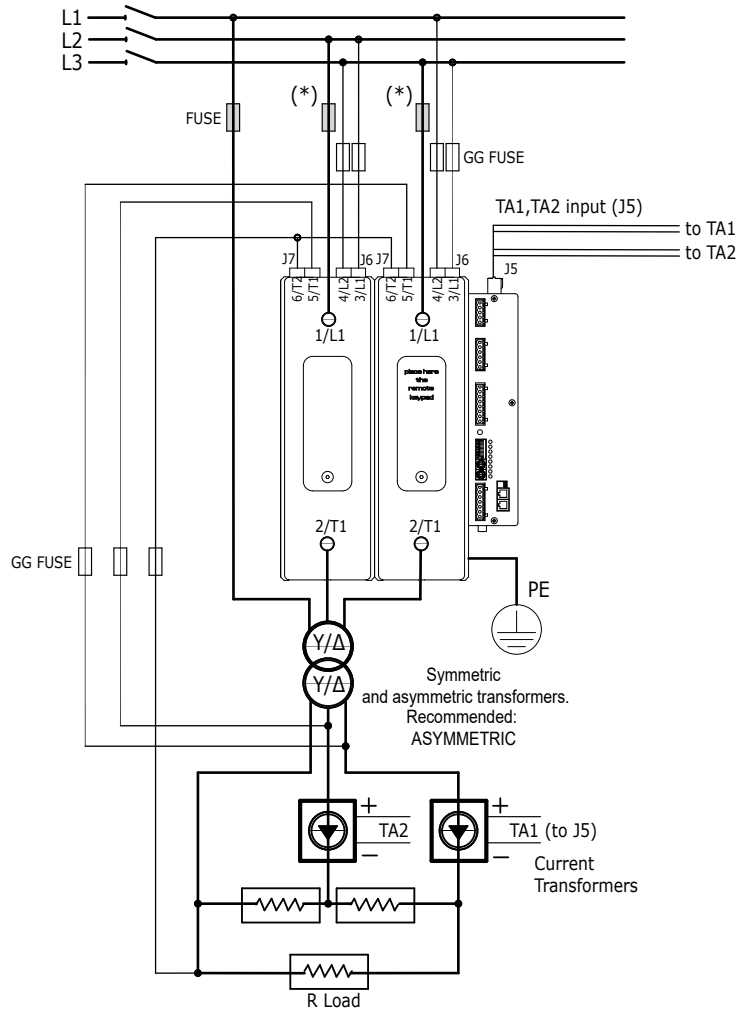

Thyritop 600 - DIP switch configuration				
DIP 1	DIP 2	DIP 3	DIP 4	DIP 5
ON	OFF	ON	OFF	ON

<b>V</b>	Phase-to-phase voltage
<b>P</b>	Total power
<b>Vload</b>	Voltage on secondary (load)
<b>Id</b>	Current in primary
<b>Is</b>	Current in secondary
<b>η</b>	Transformer output (typical 0.9) if resistive load $\cos \varphi=1$

**CAUTION**  
 (\*): Take care to connect terminals 1/L1 and 3/L1 to the same phase

<b>FIRING MODE</b>	ZC, BF
<b>HB DIAGNOSTICS AVAILABLE</b>	Total load break
<b>Fuse</b>	Ultra-rapid fuse only required for controls with option Fuse = 0
<b>GG fuse</b>	See Fuse sections

### 3.7.8. Connection example for three-phase Thyritop 600 (3PH) for 3 independent single-phase loads

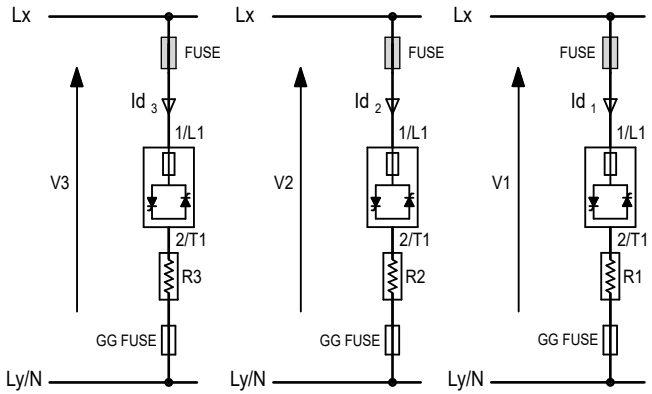
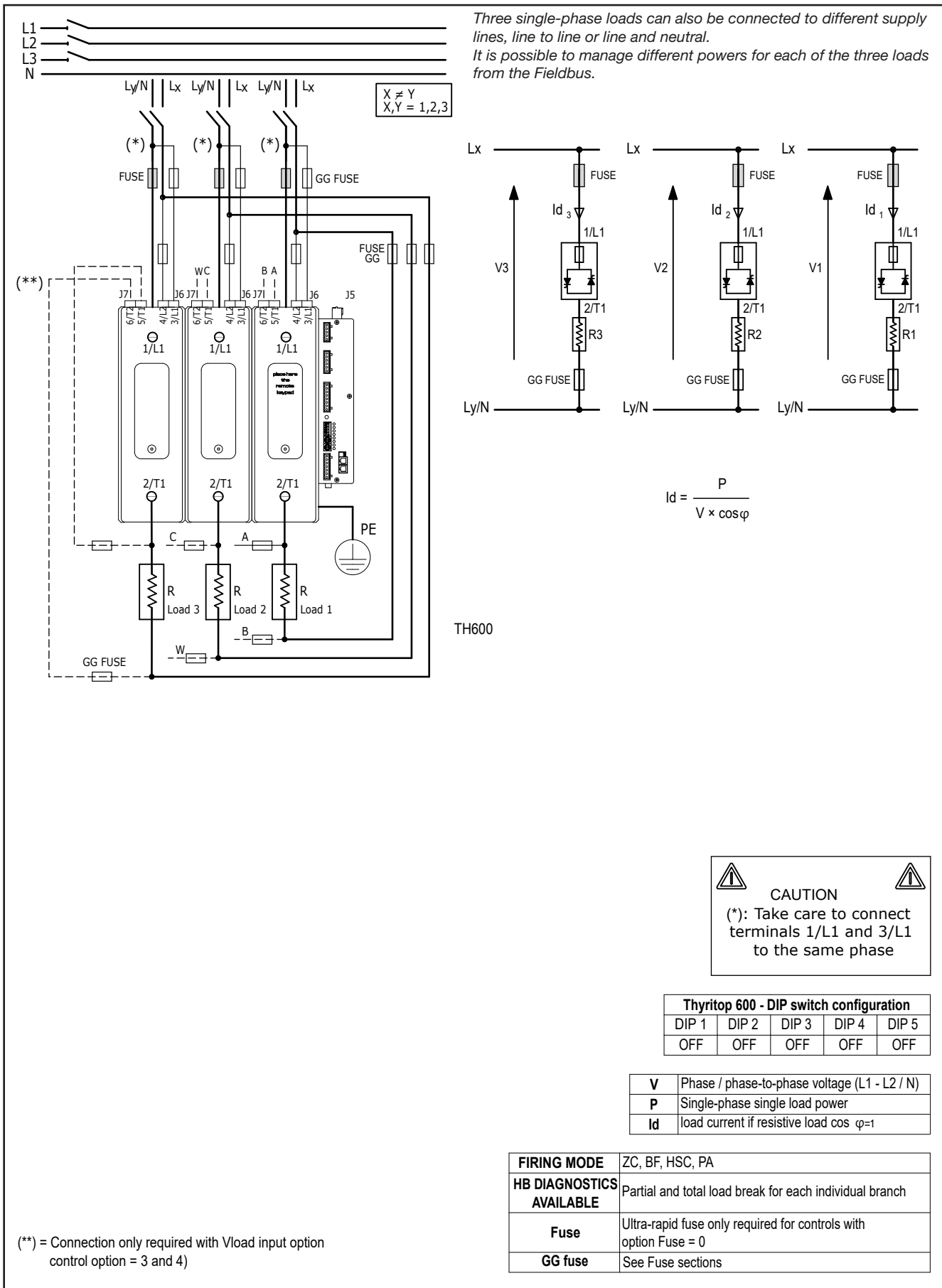

$$I_d = \frac{P}{V \times \cos \varphi}$$

### 3.7.9. Connection example for three-phase Thyritop 600 (3PH) for a three-phase star load with neutral

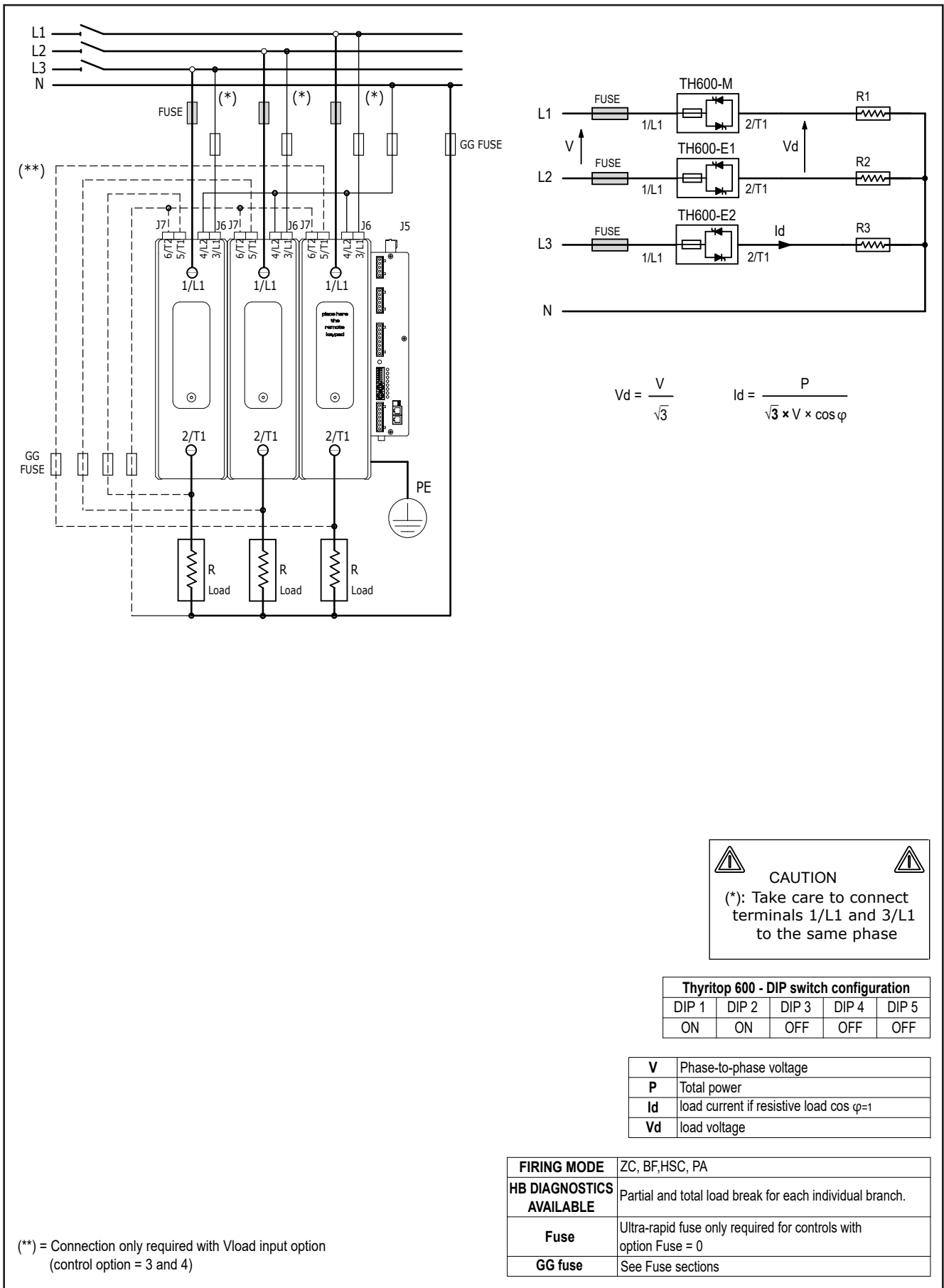

### 3.7.10. Connection example for three-phase Thyritop 600 (3PH) for a three-phase star load without neutral

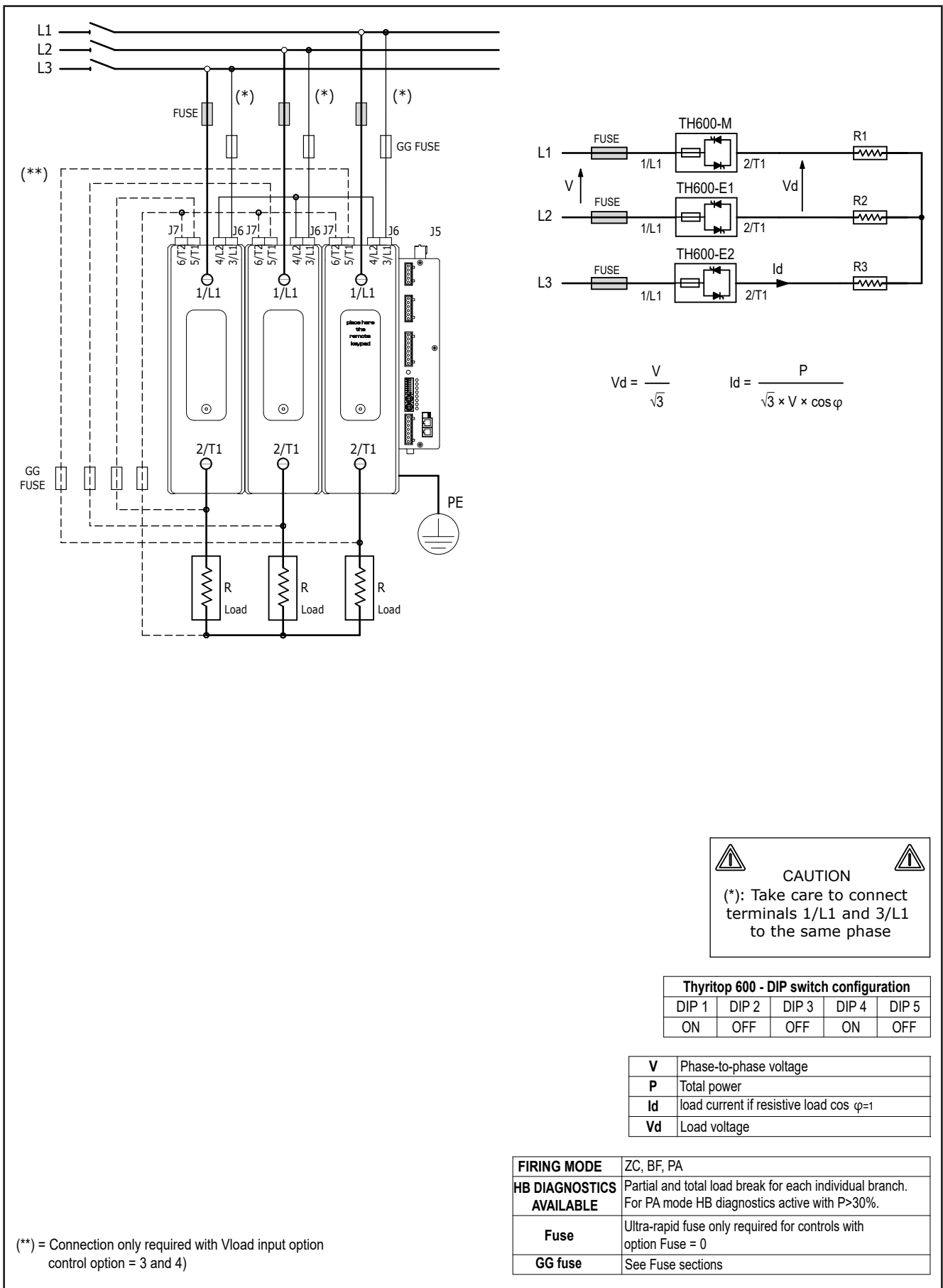

**3.7.11. Connection example for three-phase Thyritop 600 (3PH) for a three-phase star load without neutral with transformer**

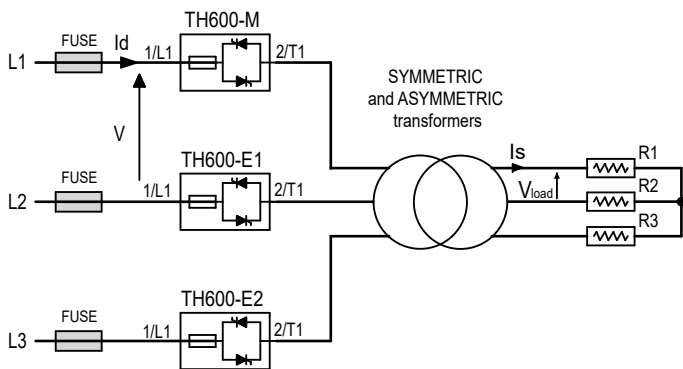
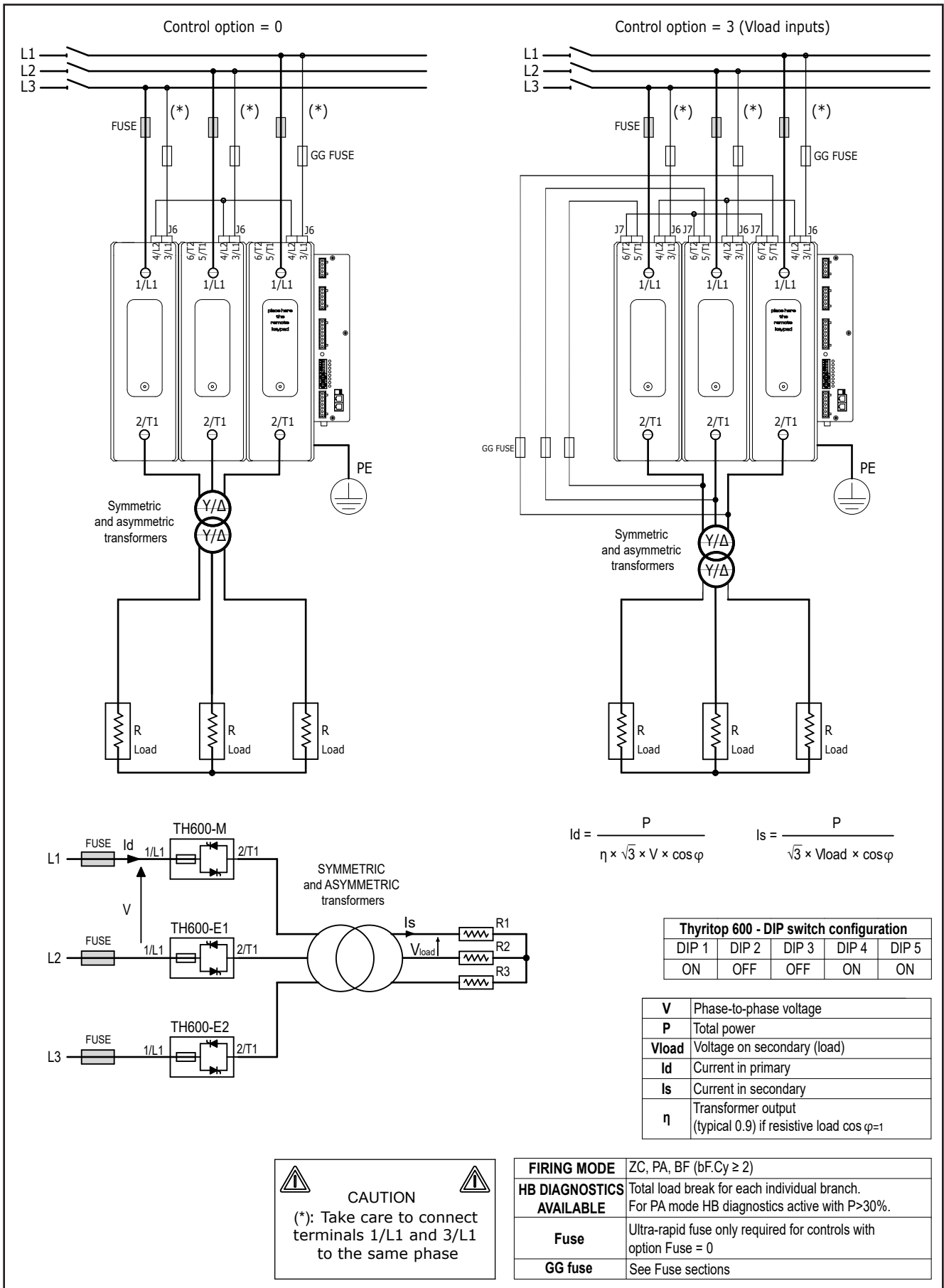

$$I_d = \frac{P}{\eta \times \sqrt{3} \times V \times \cos \varphi} \quad I_s = \frac{P}{\sqrt{3} \times V_{load} \times \cos \varphi}$$

Thyritop 600 - DIP switch configuration				
DIP 1	DIP 2	DIP 3	DIP 4	DIP 5
ON	OFF	OFF	ON	ON

<b>V</b>	Phase-to-phase voltage
<b>P</b>	Total power
<b>Vload</b>	Voltage on secondary (load)
<b>I<sub>d</sub></b>	Current in primary
<b>I<sub>s</sub></b>	Current in secondary
<b>η</b>	Transformer output (typical 0.9) if resistive load $\cos \varphi = 1$

**CAUTION**  
 (\*): Take care to connect terminals 1/L1 and 3/L1 to the same phase

<b>FIRING MODE</b>	ZC, PA, BF (bF.Cy ≥ 2)
<b>HB DIAGNOSTICS AVAILABLE</b>	Total load break for each individual branch. For PA mode HB diagnostics active with P>30%.
<b>Fuse</b>	Ultra-rapid fuse only required for controls with option Fuse = 0
<b>GG fuse</b>	See Fuse sections



Control option = 4 (Vload inputs and external CT inputs)

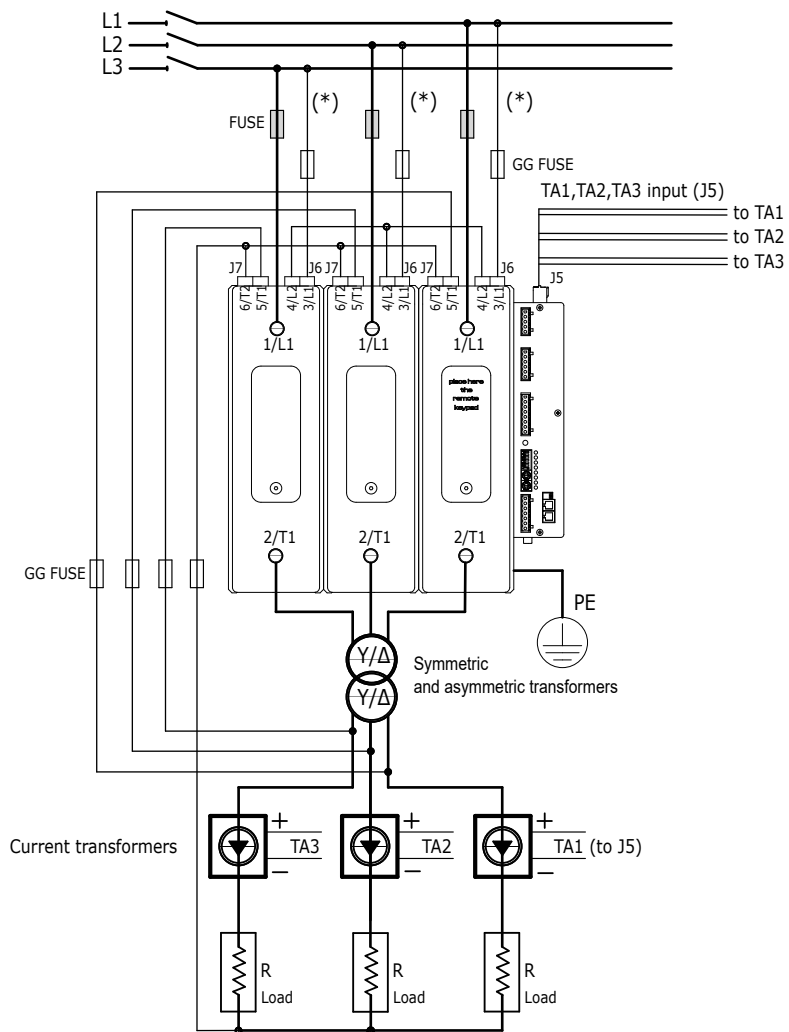

Thyritop 600 - DIP switch configuration				
DIP 1	DIP 2	DIP 3	DIP 4	DIP 5
ON	OFF	OFF	ON	ON

<b>V</b>	Phase-to-phase voltage
<b>P</b>	Total power
<b>Vload</b>	Voltage on secondary (load)
<b>Id</b>	Current in primary
<b>Is</b>	Current in secondary
<b>η</b>	Transformer output (typical 0.9) if resistive load $\cos \varphi=1$

**CAUTION**  
 (\*): Take care to connect terminals 1/L1 and 3/L1 to the same phase

<b>FIRING MODE</b>	ZC, PA BF (bF.Cy $\geq 2$ )
<b>HB DIAGNOSTICS AVAILABLE</b>	Total load break for each individual branch. For PA mode HB diagnostics active with $P > 30\%$ .
<b>Fuse</b>	Ultra-rapid fuse only required for controls with option Fuse = 0
<b>GG fuse</b>	See Fuse sections

### 3.7.12. Connection example for three-phase Thyritop 600 (3PH) for three-phase closed delta load

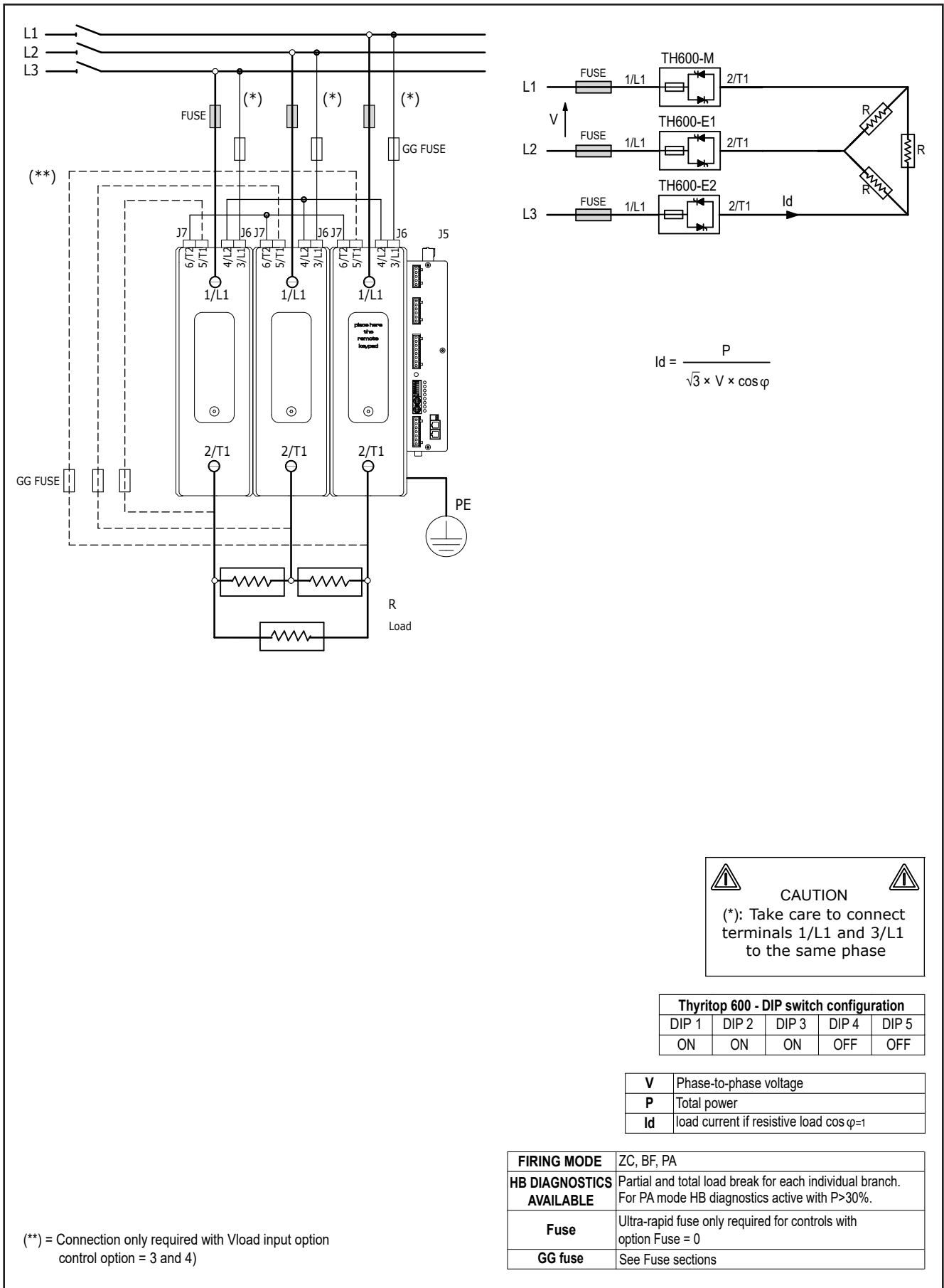

### 3.7.13. Connection example for three-phase Thyritop 600 (3PH) for a three-phase closed delta load with transformer

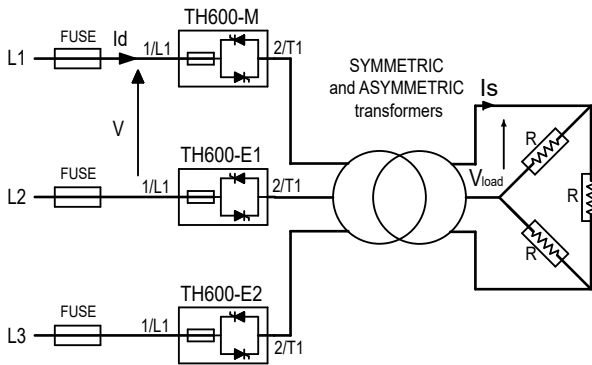
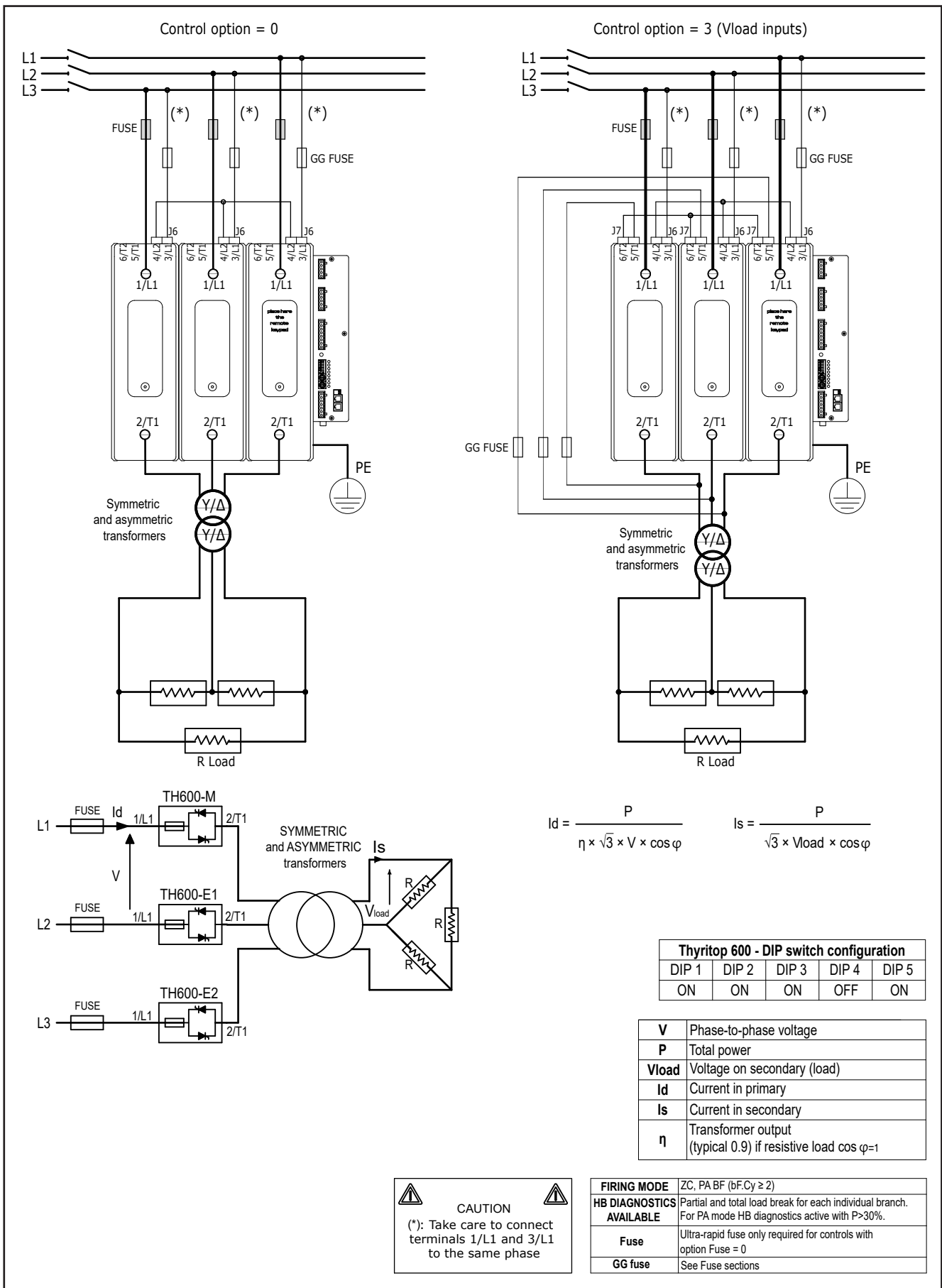

$$I_d = \frac{P}{\eta \times \sqrt{3} \times V \times \cos \varphi} \quad I_s = \frac{P}{\sqrt{3} \times V_{load} \times \cos \varphi}$$

Thyritop 600 - DIP switch configuration				
DIP 1	DIP 2	DIP 3	DIP 4	DIP 5
ON	ON	ON	OFF	ON

<b>V</b>	Phase-to-phase voltage
<b>P</b>	Total power
<b>Vload</b>	Voltage on secondary (load)
<b>I<sub>d</sub></b>	Current in primary
<b>I<sub>s</sub></b>	Current in secondary
<b>η</b>	Transformer output (typical 0.9) if resistive load $\cos \varphi=1$

**CAUTION**  
 (\*): Take care to connect terminals 1/L1 and 3/L1 to the same phase

<b>FIRING MODE</b>	ZC, PA BF (bF.Cy ≥ 2)
<b>HB DIAGNOSTICS AVAILABLE</b>	Partial and total load break for each individual branch. For PA mode HB diagnostics active with P>30%.
<b>Fuse</b>	Ultra-rapid fuse only required for controls with option Fuse = 0
<b>GG fuse</b>	See Fuse sections

Control option = 4 (Vload inputs and external CT inputs)

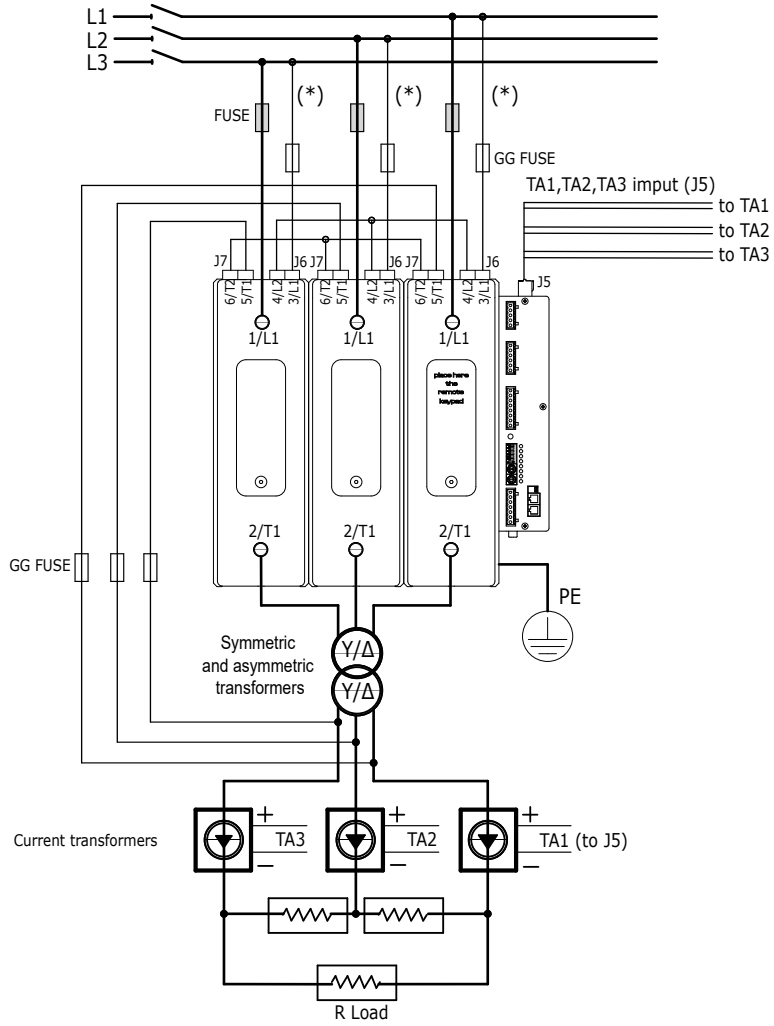

Thyritop 600 - DIP switch configuration				
DIP 1	DIP 2	DIP 3	DIP 4	DIP 5
ON	ON	ON	OFF	ON

<b>V</b>	Phase-to-phase voltage
<b>P</b>	Total power
<b>Vload</b>	Voltage on secondary (load)
<b>Id</b>	Current in primary
<b>Is</b>	Current in secondary
<b>η</b>	Transformer output (typical 0.9) if resistive load $\cos \varphi=1$

**CAUTION**  
 (\*): Take care to connect terminals 1/L1 and 3/L1 to the same phase

<b>FIRING MODE</b>	ZC, PA, BF (bF.Cy ≥ 2)
<b>HB DIAGNOSTICS AVAILABLE</b>	Partial and total load break for each individual branch. For PA mode HB diagnostics active with P>30%.
<b>Fuse</b>	Ultra-rapid fuse only required for controls with option Fuse = 0
<b>GG fuse</b>	See Fuse sections

### 3.7.14. Connection example for three-phase Thyritop 600 (3PH) for three-phase open delta load

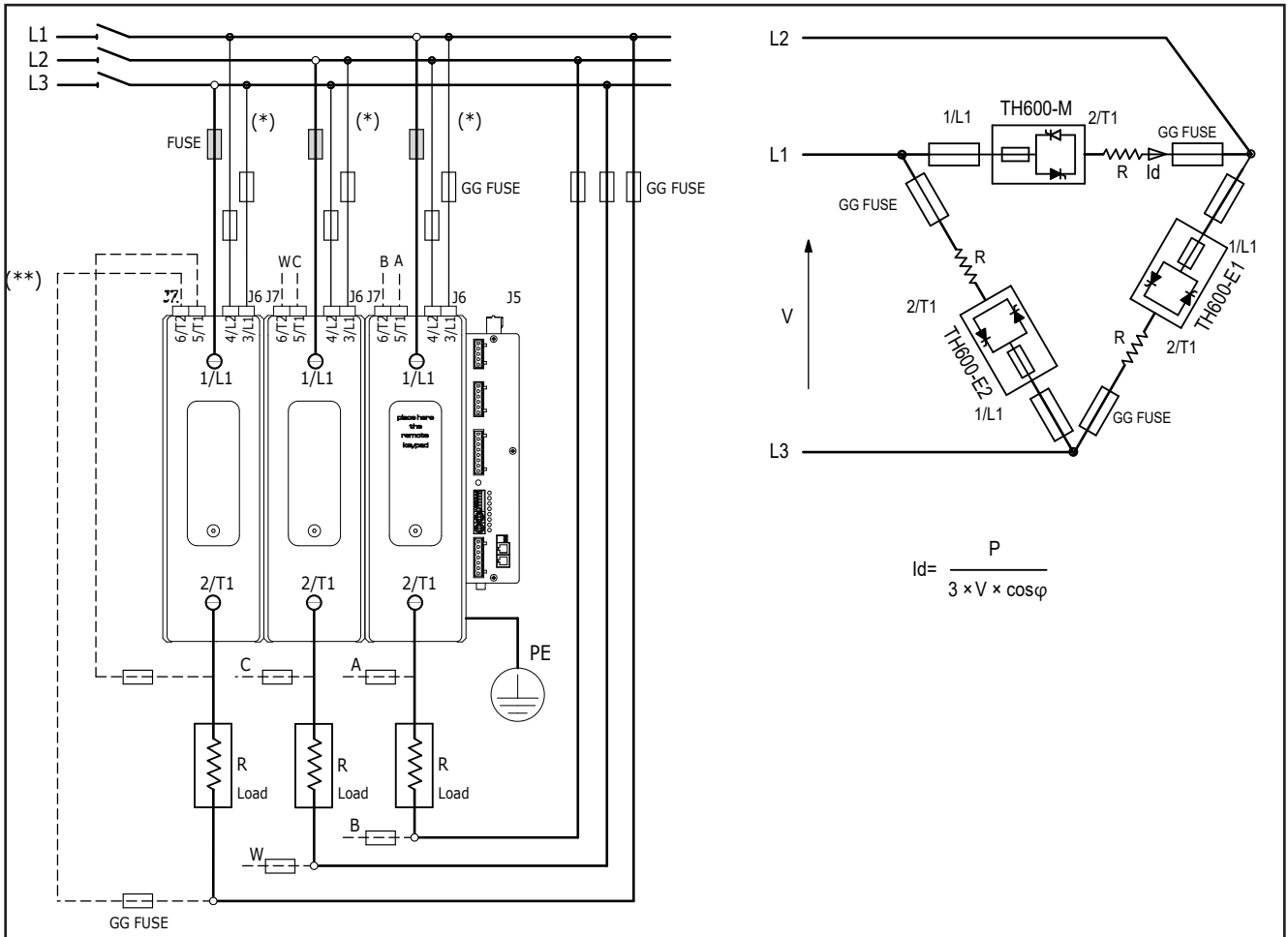

$$I_d = \frac{P}{3 \times V \times \cos \varphi}$$

**CAUTION**  
 (\*): Take care to connect terminals 1/L1 and 3/L1 to the same phase

Thyritop 600 - DIP switch configuration				
DIP 1	DIP 2	DIP 3	DIP 4	DIP 5
ON	ON	OFF	OFF	OFF

<b>V</b>	Phase-to-phase voltage
<b>P</b>	Power of each individual phase
<b>I<sub>d</sub></b>	Load current if resistive load cos φ=1

<b>FIRING MODE</b>	ZC, BF, HSC, PA
<b>HB DIAGNOSTICS AVAILABLE</b>	Partial and total load break for each individual branch.
<b>Fuse</b>	Ultra-rapid fuse only required for controls with option Fuse = 0
<b>GG fuse</b>	See Fuse sections

(\*\*) = Connection only required with Vload input option (control option = 3 and 4)

**3.7.15. Connection example for three-phase Thyritop 600 (3PH) for 3 independent loads in open delta**

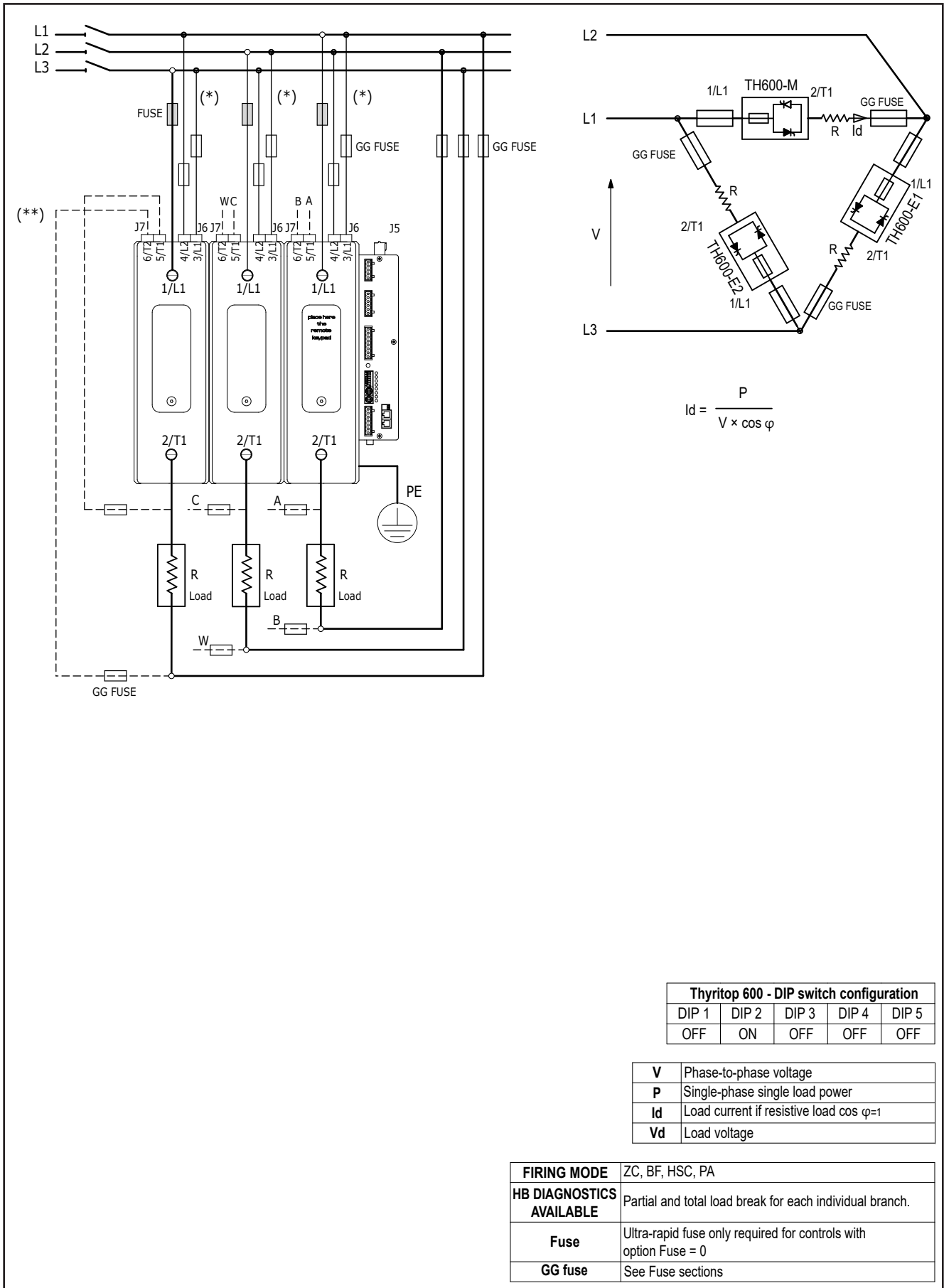

---

### 3.8. Notes on use with inductive loads and transformers

---

- When the Thyritop 600 controller is in operation, it is NOT permissible to disconnect the connection between the Thyritop 600 and the transformer or between the transformer and the load.
- The maximum current that can be controlled by the Thyritop 600 is reduced compared to the nominal value of the device (see technical specifications).
- In ZC and BF trigger modes use the delay-triggering function to limit the peak magnetising current.
- In PA trigger mode use softstart function
- DO NOT use the HSC trigger mode.
- Do not connect RC snubbers in parallel to the transformer primary.
- Always set DIP switch No. 5 to ON (and carry out the initial configuration procedure described in paragraph “1.6.2. Initialisation procedure and loading of default values”).

## 4. OPERATING MODES

### 4.1. Trigger modes

For power control the Advanced Power Controller provides the following modes:

- modulation through variation of the number of conduction cycles with “zero crossing” triggering;
- modulation through variation of the phase angle.

#### 4.1.1. “Zero crossing” mode

This is a type of operation that eliminates EMC interference. This mode manages load power through a series of ON operating cycles rather than OFF operating cycles.

##### 4.1.1.1. ZC - constant cycle time

Applies to  $T_c \geq 1$  second (settable from 1 to 200 seconds). The cycle time is divided into a series of conduction and non-conduction cycles in the same ratio as the power to be transferred to the load (see figure). For example, if  $T_c = 10$  seconds and if the power value is

20%, we will have conduction for 2 seconds (100 conduction cycles @ 50Hz) and non-conduction for 8 seconds (400 non-conduction cycles @ 50Hz).

##### 4.1.1.2. BF - variable cycle time

This mode manages the power on the load through a series of conduction (ON) cycles rather than non-conduction (OFF) cycles. The ratio of the number of ON cycles to the number of OFF cycles is proportional to the value of the power to be supplied to the load.

Setting parameter, Bf.cy, is the minimum number of conduction cycles (whereas in ZC mode this period is always fixed and not optimised).

A parameter defines the minimum number of conduction cycles that can be set from 1 to 10. In the example shown in the figure, this parameter is = 2.

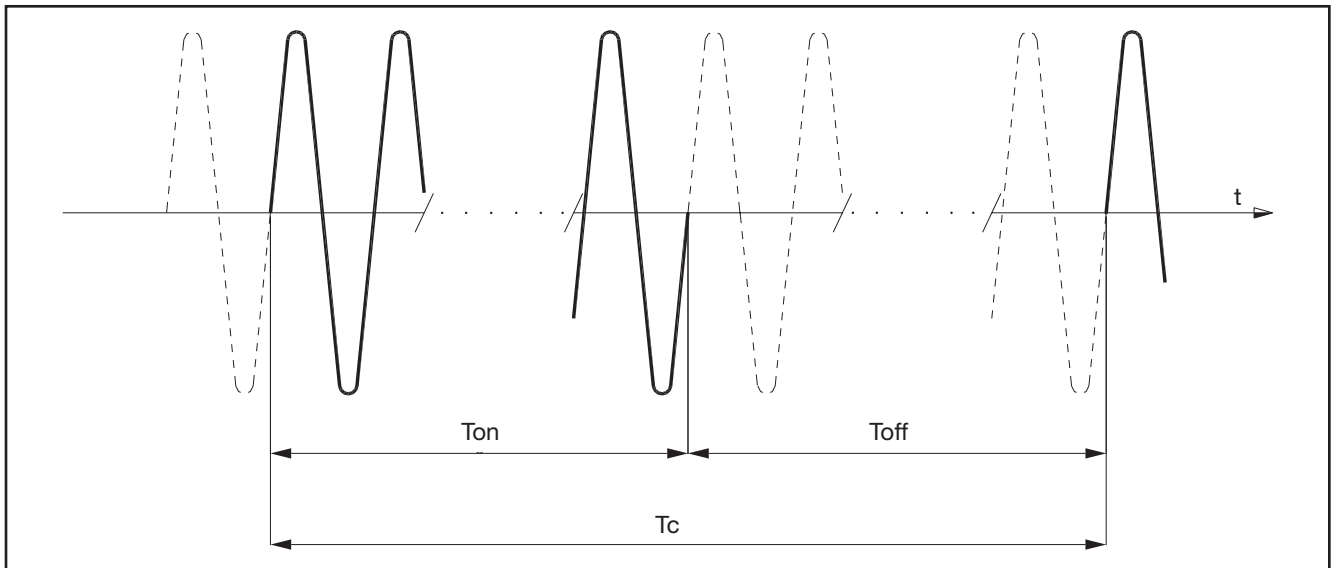

Figure 20 - Example of operation in ZC mode

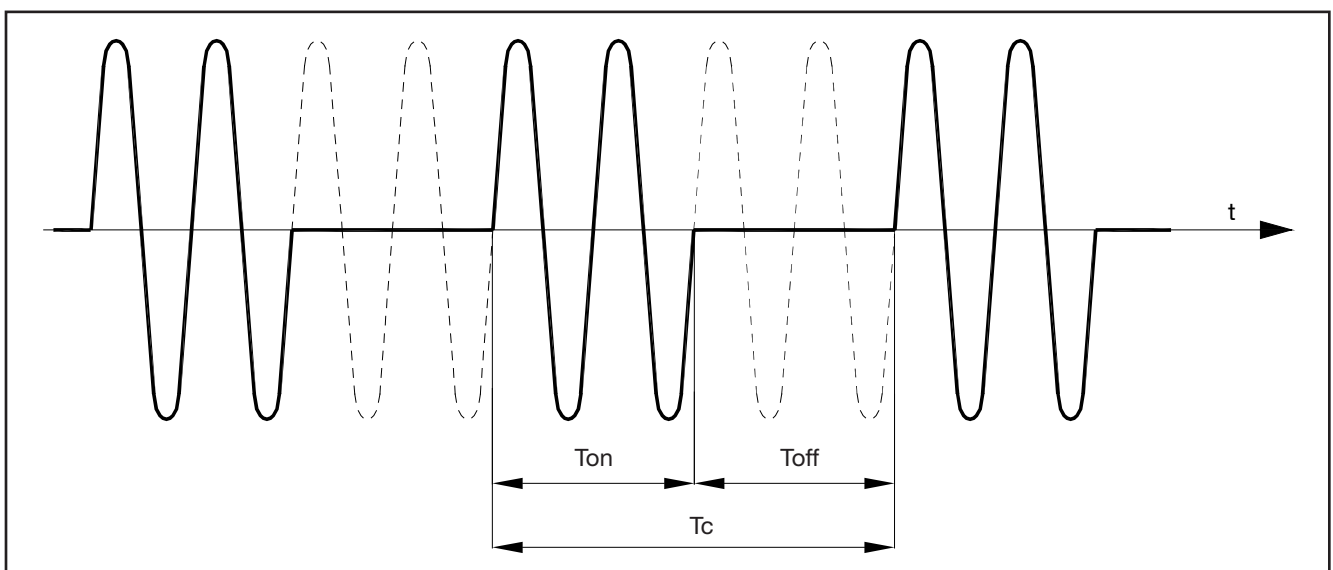

Figure 21 - Example of operation in BF mode at 50% power



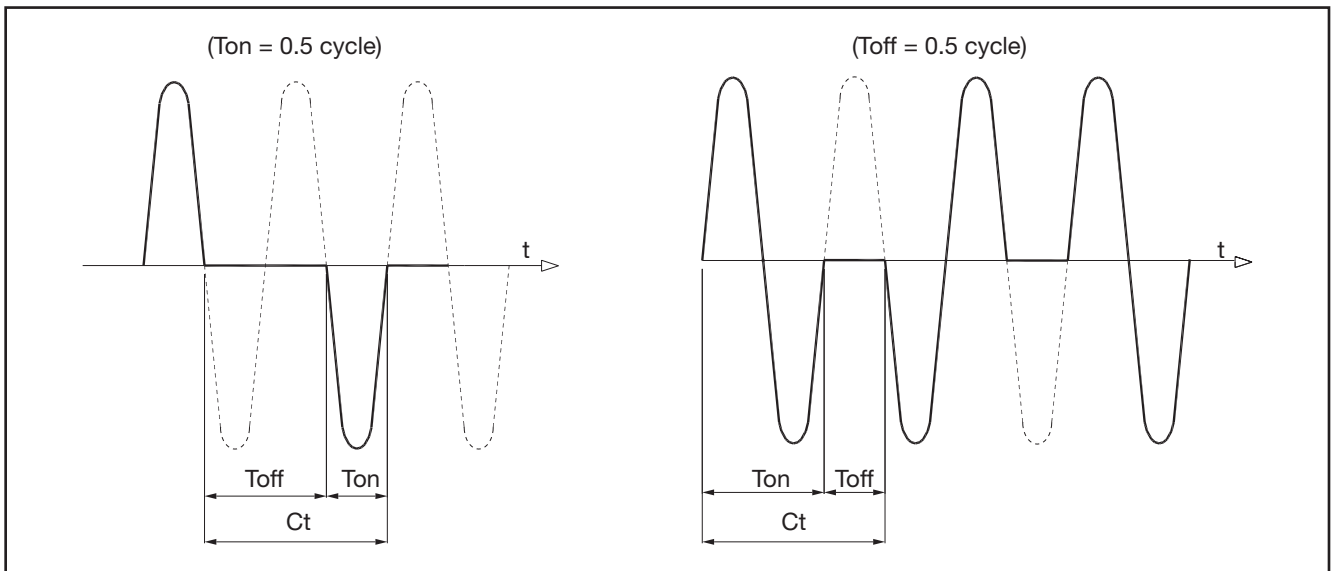

Figure 22 - Example of operation in HSC mode at 33% and 66% power

#### 4.1.1.3. HSC - Half single cycle

This mode corresponds to Burst Firing, which handles on/off semi-cycles. It is useful for reducing filament flickering with short/medium wave IR lamp loads. With such loads, in order to limit the steady state current with low power, it is useful to set a minimum power limit (e.g., Lo.P = 10%, see "Programming manual").

**CAUTION!** This operating mode is NOT permitted with inductive loads (transformers), it is used with resistive loads in single-phase, star with neutral or open delta configuration.

#### 4.1.2. Phase angle (PA)

This mode manages the power on the load by modulating the trigger angle  $q$ :

- if the power to be transferred to the load is 100%,  $q = 180^\circ$ ;
- if the power to be transferred to the load is 50%,  $q = 90^\circ$ .

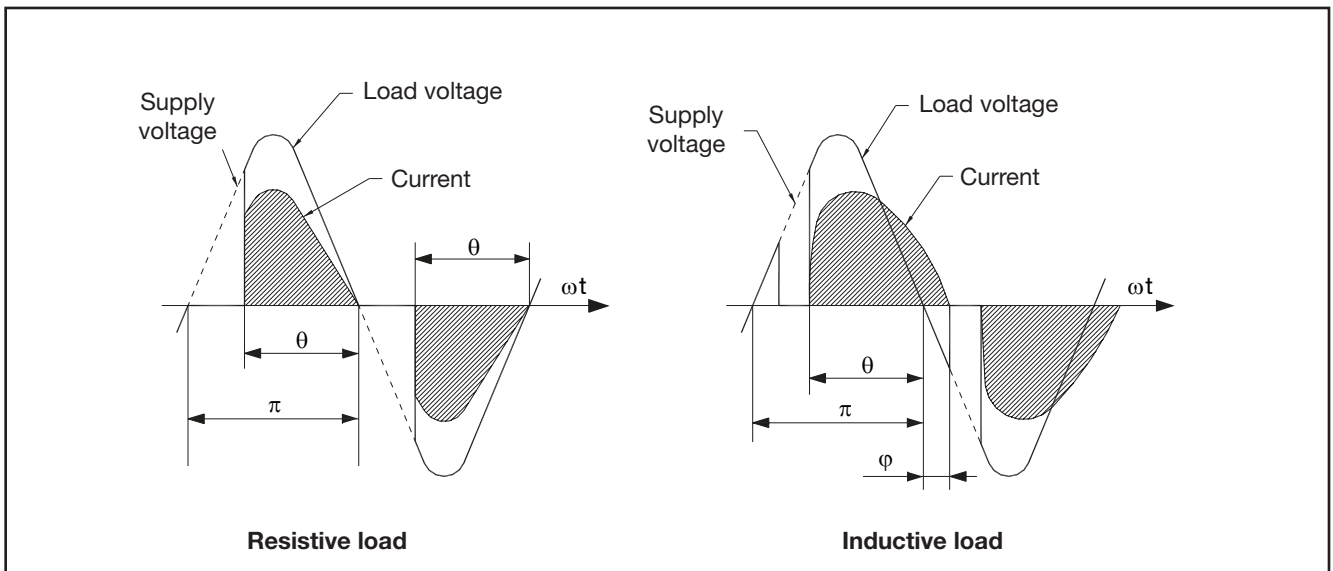

Figure 23 - Example of operation in Phase Angle (PA) mode

## 4.2. Additional functions

### 4.2.1. Softstart

This type of start can be enabled either in phase control mode or in zero-crossing mode (ZC, BF, HSC,PA).

In the case of phase control, the increase in the conduction angle  $q$  stops at the corresponding value of the power to be transferred to the load.

Control of maximum peak current can be enabled during softstart (useful in the event of a short circuit on the load or loads with high temperature coefficients, to automatically adjust start time to the load).

When the load shut-off time (settable) is exceeded, the ramp is reactivated at the next power-on.

### 4.2.2. RMS current limit

The option to control the load current limit is available in all operating modes.

If the current value exceeds the limit (settable in the nominal full-scale range) in PA mode the conduction angle is limited, while in zero-crossing mode (ZC, BF, HSC) the cycle time conduction percentage is limited.

This limitation ensures that the RMS value (i.e., not the instantaneous value) of the load current does NOT exceed the set RMS current limit.

The illustration shows an example of limiting the conduction angle in PA mode to comply with an RMS current limit that is less than the nominal load current.

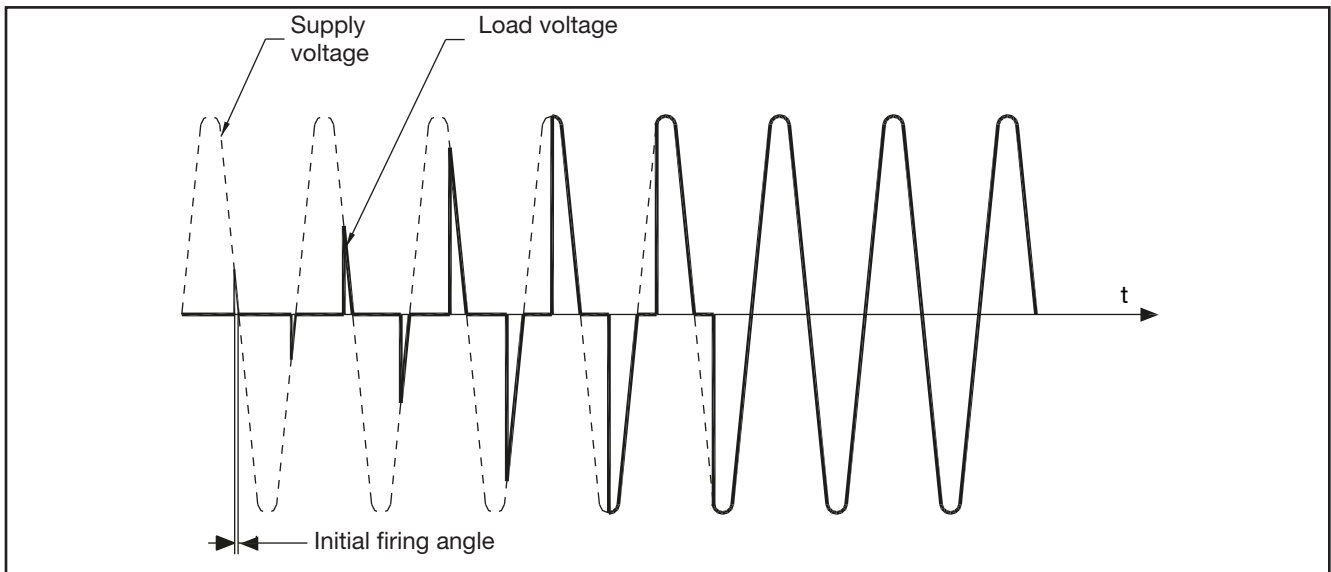

Figure 24 - Firing ramp with phase softstart

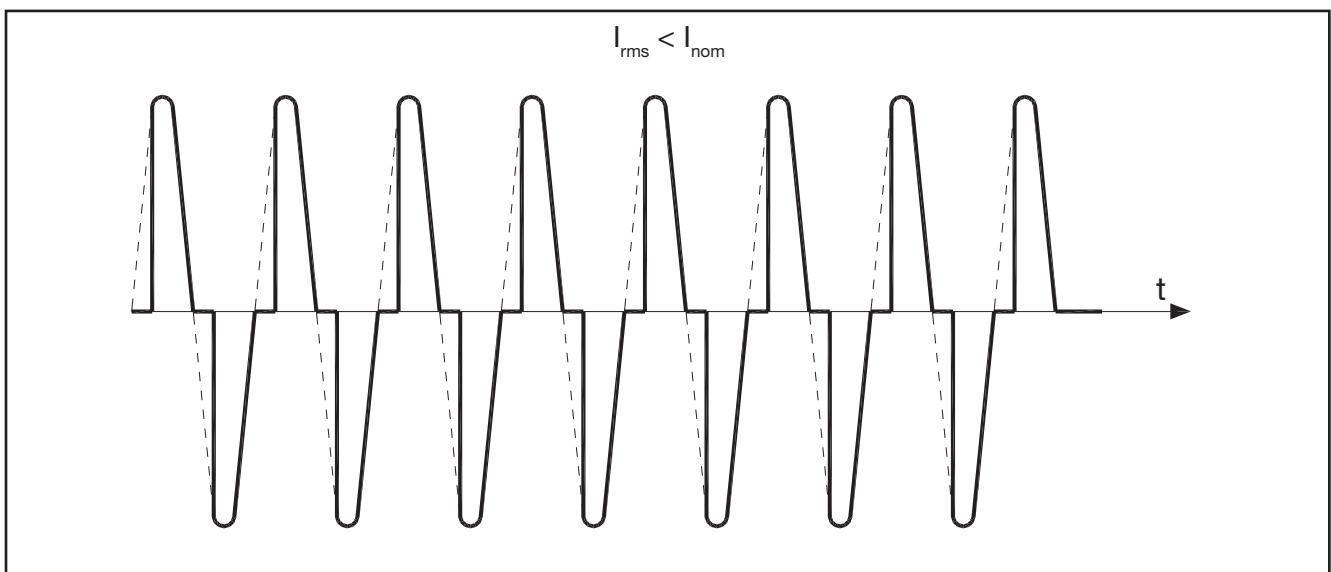

Figure 25 - Example of conduction angle limitation in PA mode

### 4.2.3. DT - Delay triggering

The triggering delay (only for control modes ZC, BF) can be set from  $0^\circ$  to  $90^\circ$ .

It is useful for inductive loads (transformer primaries), to prevent a current peak that could in some cases trip the ultra-rapid fuses protecting the SCRs.

The figure shows how an inductive load is switched on with and without delay-triggering.

The phase softstart ramp is used instead of delay triggering for firing inductive loads managed in PA (Phase Angle) mode.

The example in the figure compares the methods of starting a transformer: Softstart ramp (for PA mode) and Delay triggering (for ZC and BF modes).

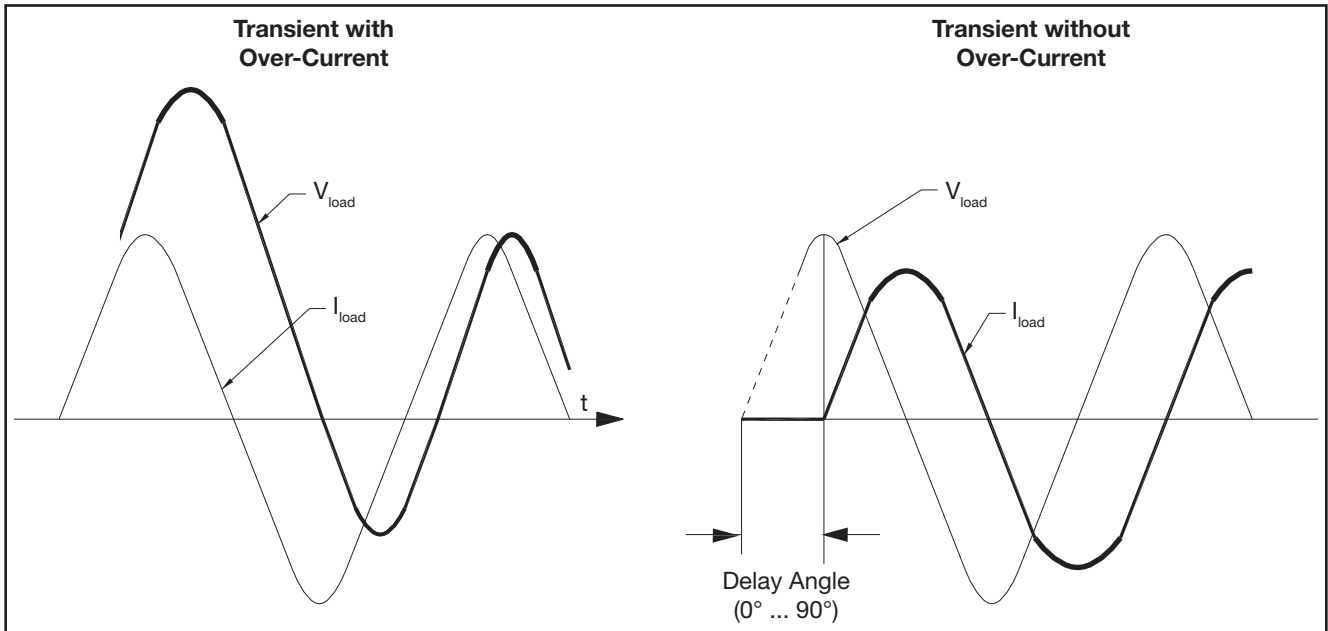

Figure 26 - Switching on an inductive load

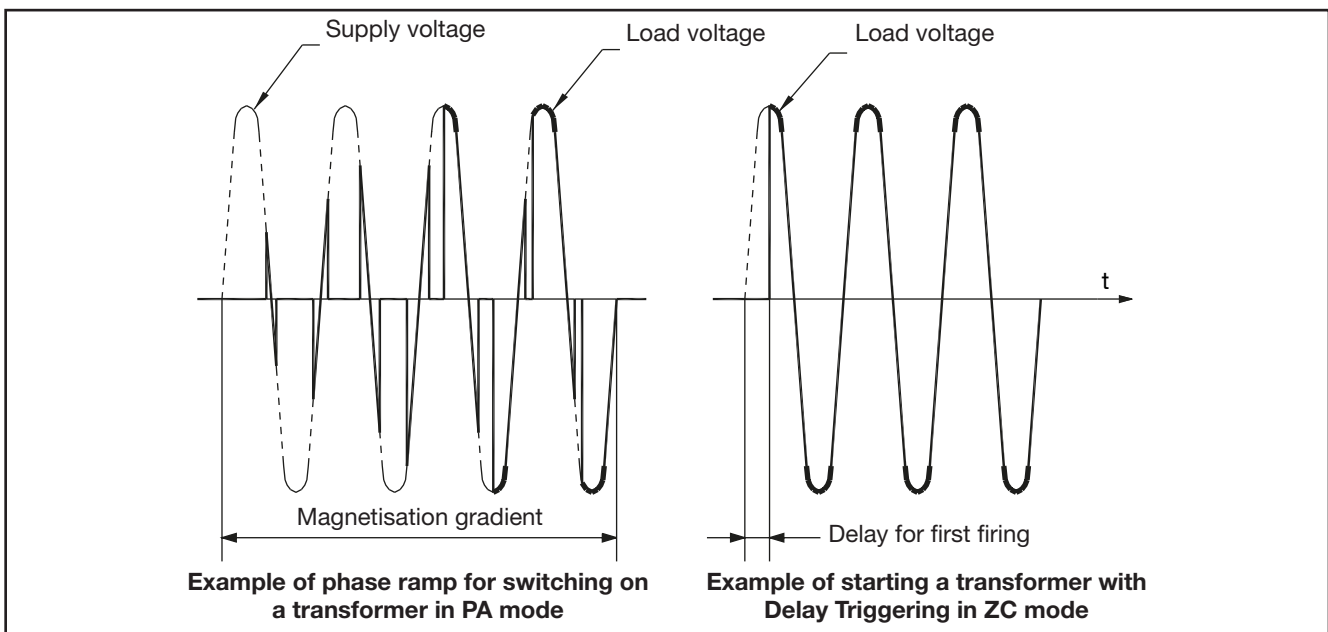

Figure 27 - Various modes of switching on an inductive load

### 4.3. Digital input (PWM)

The PWM digital input can be used to receive information on the percentage (%) of power to be supplied to the load (see the Configuration and Programming Manual for digital input configuration).

The signal can be generated by an external controller or external PLC via digital outputs (logic output for Pyrocontrol instruments).

This is achieved by alternating the status of the output in ON for time TON with the output in OFF for time TOFF. The sum of TON+TOFF is constant and is called Cycle Time.

$$\text{Cycle Time} = \text{TON} + \text{TOFF}$$

The power level is given by the ratio TON/Cycle Time and is normally expressed in %.

The Thyritop 600's INDIG1 digital input automatically adapts to the cycle time from 0.03 Hz to 100 Hz and obtains the power percentage level (%) to be supplied to the load from the ratio TON/(TON+TOFF).

NOTE: For INDIG2 and INDIG3 inputs, the maximum PWM frequency is limited to 1 Hz. INDIG4, however, is not configurable as a PWM input.

#### Connection example

In the following connection example, the Pyrocontrol instrument controls the temperature and sends the control signal from the D type logic output (Out2) to the DIG1 input of Thyritop 600-M.

The cycle time is 0.1seconds.

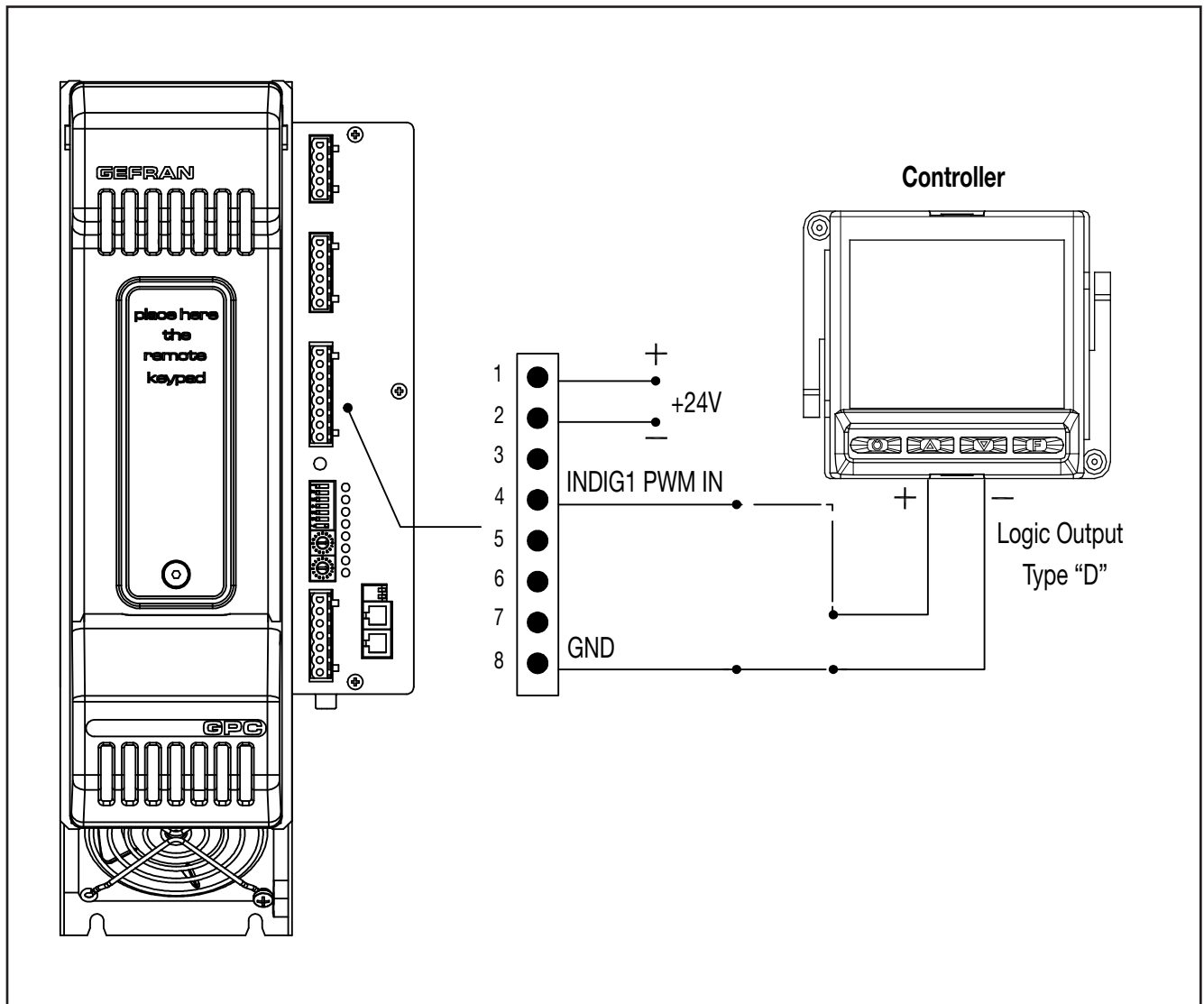

Figure 28 - Example of external controller connection

## 5. USING PORT 1 “MODBUS RTU”

A network typically has a Master that “manages” communication by means of “commands,” and Slaves that carry out these

commands.

Thyritop 600 should be considered as a Slave to the network Master, which is normal a supervisory terminal or a PLC. It is uniquely identified by a node address (ID) set on the rotary switches (tens + units). Up to 99 Thyritop 600 modules can be installed in a serial network, with node address selectable from ‘01’ to ‘99’. The use of the letters (A...F) on the rotary switches is reserved.

Thyritop 600 has a Modbus RTU serial port (PORT 1) an optional serial port (see ordering code) for the Fieldbus (PORT 2). The Fieldbus can use one of the following protocols: Modbus RTU, Profibus DP, CANopen, Profinet, Ethernet/IP and Ethernet Modbus TCP.

PORT 1, the Modbus RTU port, has the following factory settings (default):

Parameter	Default	Range
ID	1	1...99
BaudRate	19.2 kbit/s ...	1200...115 kbit/s
Parity	None	Odd/Even/None
StopBits	1	-
DataBits	8	-

The use of the letters (A...F) on the rotary switches is reserved.

### 5.3.1. “AutoBaud Port 1” procedure

The AutoBaud procedure allows the correct BaudRate value to be set automatically by detecting the Master’s transmission frequency.

This procedure is essential for the correct use of the PORT 1 Modbus RTU port. The serial communication speed and parity of the Thyritop 600 modules must always be adjusted to the connected supervision terminal or PLC.

AutoBaud is executed on the Thyritop 600 as follows:

1. Connect the serial cables to all modules in the network on PORT 1 and to the supervision terminal.
2. Set the rotary switch on the Thyritop 600 modules to be installed, or on all modules present in case of first installation, to position “0+0”.
3. Check that the green “STATUS” LED flashes at a high frequency (10 Hz).
4. The supervision terminal must send a series of generic “MODBUS” read messages to the network.
5. The procedure is complete when all the green L1 “STATUS” LEDs on the Thyritop 600 modules flash at a normal frequency (2 Hz). NOTE: The frequency is valid if parameter 197 *Ld.1* is equal to 16 by default.
6. The new speed parameter is permanently saved in each Thyritop 600; therefore the “AUTOBAUD SERIAL” sequence does not have to be run in subsequent power-ups.

NOTES:

- When the rotary switch is turned, the green “STATUS” LED stays on for about 6 seconds, after which it resumes normal operation and saves the address.
- The green LED L1 “STATUS”, mentioned in the procedure, can vary its behaviour according to the parameter *Ld.1*, which by default is equal to 16.

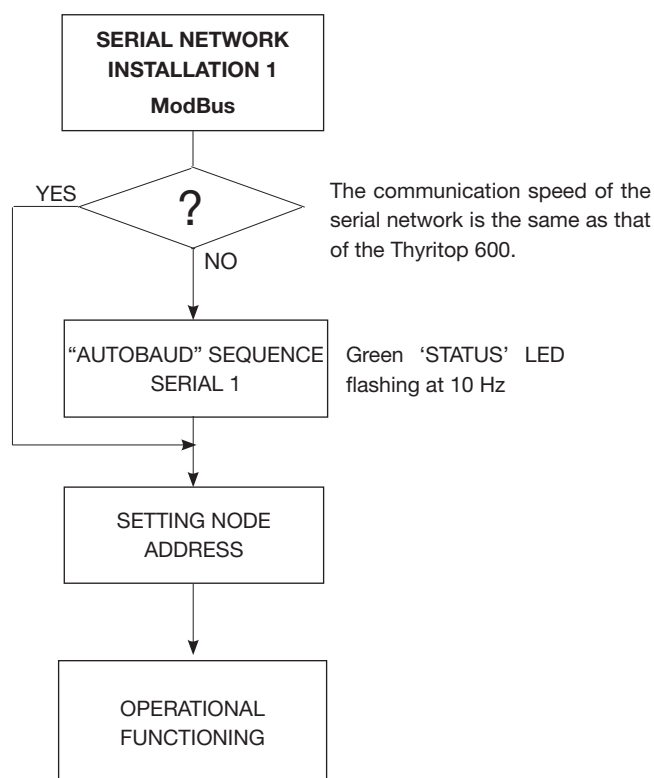

## 6. MAINTENANCE



**Caution!** Repairs to the Advanced Power Controller must only be made by technical personnel suitably trained and authorised by Pyrocontrole. Any attempt to repair or modify the hardware features of the device by unauthorised personnel will void the warranty.

### 6.1. Periodic cleaning



Clean the outside of the device using only a soft cloth. Do not use solvents derived from hydrocarbons (triethylene, benzene, etc.).



Every 6-12 months (depending on the amount of dust in the installation site), blow a jet of compressed air downward through the cooling heatsink (on the opposite side of the fan). This will clean both the heat sink and the cooling fan.

#### 6.1.1. Overtemperature alarm

Periodic cleaning helps to prevent overtemperature alarms caused by dirt that does not allow adequate heat dissipation. If the compressed air jet does not eliminate the problem, perform the following operations after first checking that the Thyritop 600 has been turned off and disconnected from the electrical power supply to ensure the operator's safety:

##### Procedure for Thyritop 600, models from 40 A to 300 A

1. Remove the fan-holder grille by releasing the 2 coupling tabs.
2. Disconnect the fan power connector from the board.
3. Check the condition of the fan. Clean it or replace it if necessary.  
**CAUTION:** before refitting the fan into the product, make sure that the arrow on it showing the air flow direction is pointing toward the dissipater.
4. Plug the fan power connector into the board.
5. Screw in the two fixing screws with a crosshead screwdriver, tightening them to a torque of 0.8 Nm.
6. Press the fan grille into place until it engages.
7. Power up the controller and check that the fan is working properly (the power must be switched on for verification)

##### Procedure for Thyritop 600 models from 400 A to 600 A

1. Extract the power supply connector from the fan.
2. Use a crosshead screwdriver to unscrew the two fixing screws on the fan.
3. Remove the fan complete with protective grille.
4. Check the condition of the fan. Clean it or replace it if necessary.  
**CAUTION:** before refitting the fan in the product, make sure that the arrow on it showing the direction of the air flow is pointing toward the dissipater.
5. Insert the fan, complete with its protective grille, centring it on the two reference pins.
6. Screw in the two fixing screws with a crosshead screwdriver, tightening them to a torque of 0.8 Nm.
7. Insert the fan's 24 V power supply cable connector.
8. Power up the controller and check that the fan is operating correctly (power must be switched on for verification).

Thyritop 600 40 A ... 300 A

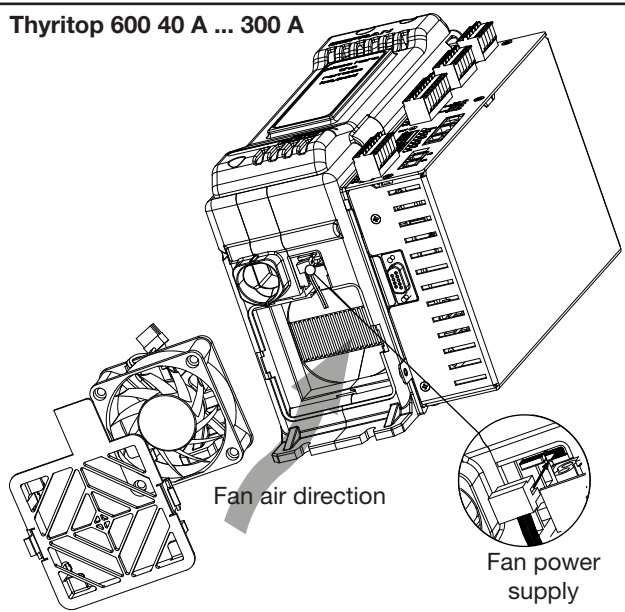

Thyritop 600 400 A ... 600 A

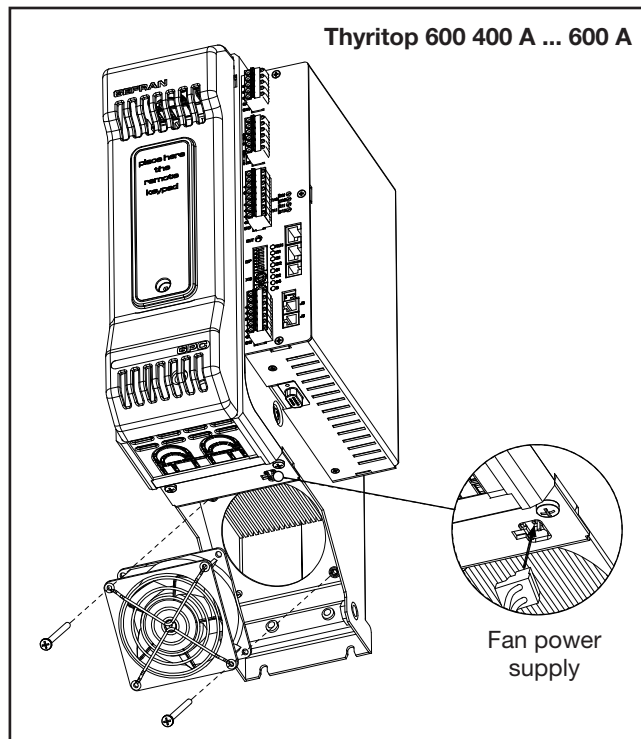

## 6.2. Replacing the internal fuse



**Caution!** Disconnect the voltage before and during the fuse replacement procedure.

The Advanced Power Controller is equipped with an internal protection fuse (optional).  
The replacement procedure and equipment required varies depending on the model.

There is no need to completely undo the nuts as the fuse is removed from its housing by sliding it out, as indicated by the arrows.

C. Insert the new fuse as indicated by the arrows.



**Caution!** ALWAYS USE AN ULTRA-RAPID FUSE.



**Caution!** The washer must remain between the nut and the fuse (NOT under the fuse), as shown in the two detailed views.

### Procedure for replacing the internal fuse in Thyritop 600 models from 40 A to 300 A

- A. Unscrew the fixing screw and remove the cover in the direction indicated by the arrow.
- B. Loosen the two fixing nuts on the fuse using a no. 13 spanner for Thyritop 600 40 A to 150 A or a no. 17 spanner for Thyritop 600 200 A to 300 A.

Tighten the two nuts to a torque of 3-4 N m.  
Put the cover back in place, inserting the top part first (paying careful attention to the coupling tooth) and secure it with its screw.

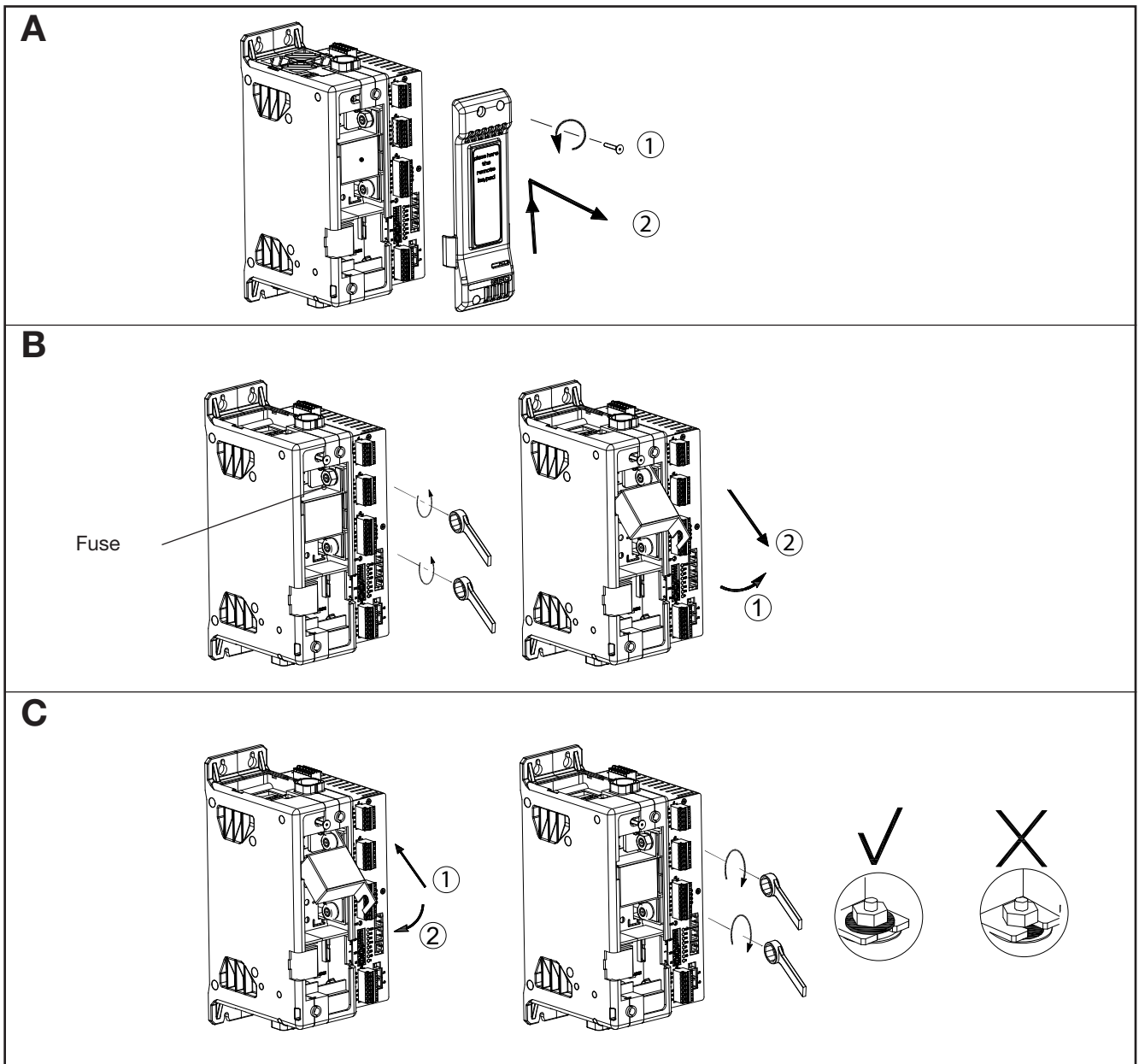



**Procedure for replacing the internal fuse in Thyritop 600 models from 400 A to 600 A**

- A. Unscrew the fixing screw and remove the cover in the direction indicated by the arrow.  
Loosen the two fixing bolts on the fuse using a no. 19 spanner for Thyritop 600 500 A and 600 A or a no. 17 spanner for Thyritop 600 400 A.  
There is no need to completely undo the nuts as the fuse is removed from its housing by sliding it outwards.
- B. Remove the fuse, as indicated by the arrow, keeping the bolts and washers from the old fuse and partially screwing them onto the new one.  
Insert the new fuse as indicated by the arrow.

**CAUTION!** The washer must be between the bolt and the copper strip (NOT under the fuse).

- C. Tighten the two nuts to a torque of 12 N m.  
Replace the cover by initially inserting it at the top first (pay careful attention to the hooking tooth) and secure it with its screw.

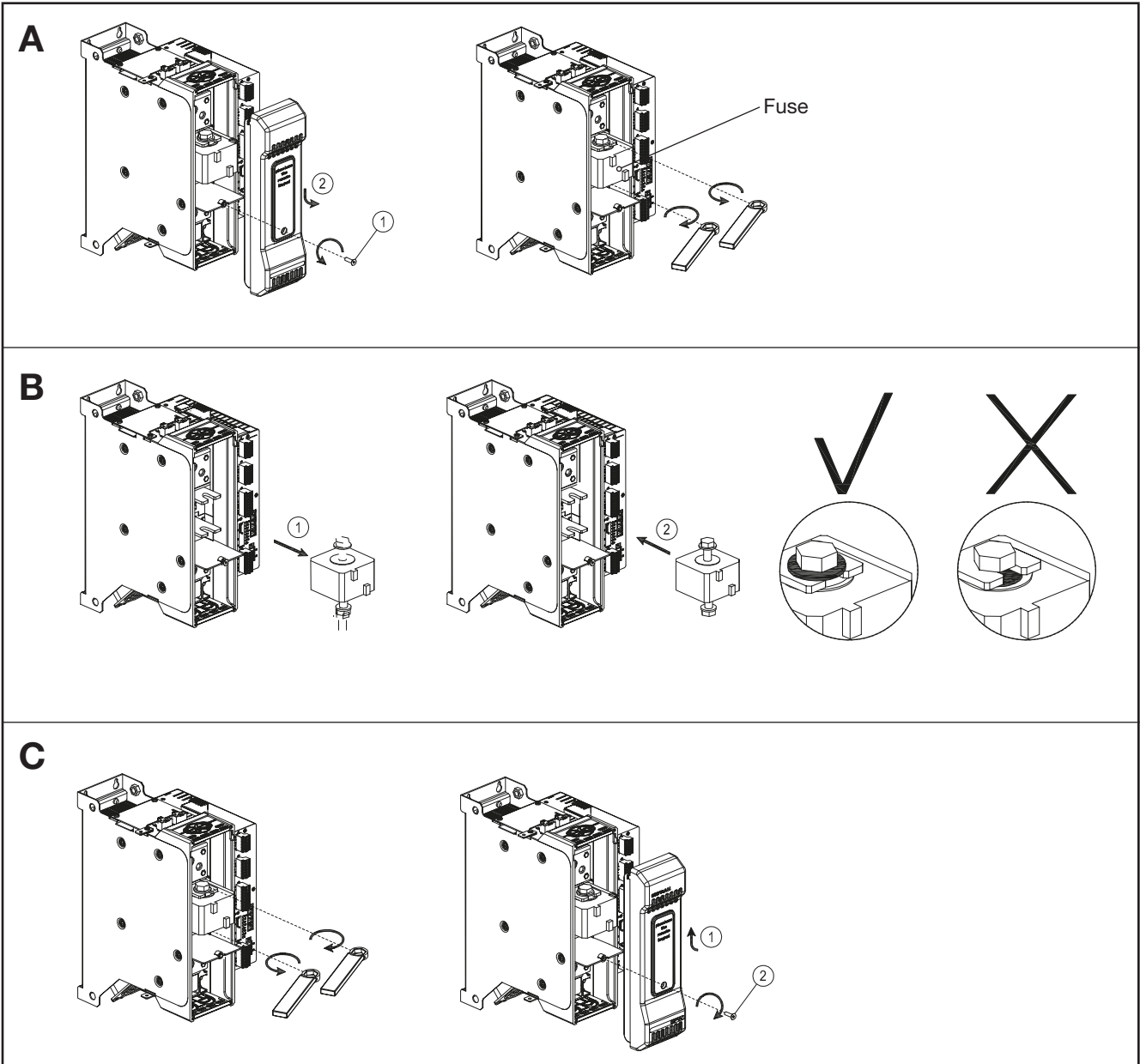



## 6.3. Replacing the fieldbus interface board



**Caution!** Disconnect the power supply before and during the board replacement procedure.



**Caution!** Use ESD protection devices to prevent the internal HW being damaged by electrostatic discharge.

5. Extract the Fieldbus interface board and insert the new one in the connectors provided on the support board. Check that the board is inserted correctly.
6. Put the CPU cover back in place and secure it by tightening the screws.

To replace the fieldbus interface board:

1. Unscrew the 3 screws on the CPU front panel.
2. Remove the CPU front panel.
3. Unscrew the 4 screws on the CPU cover.
4. Remove the CPU cover.

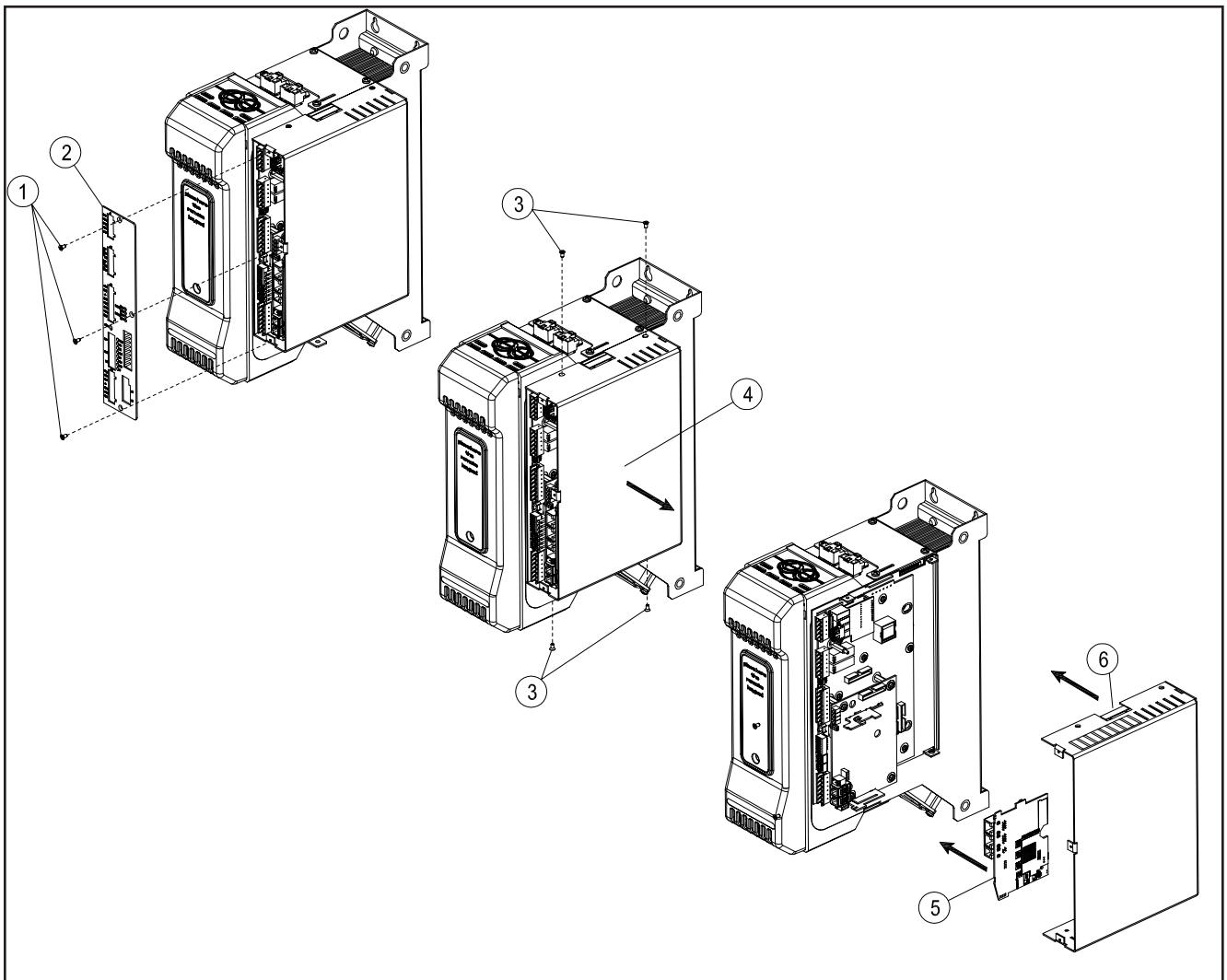

## 6.4. Disposal



The Advanced Power Controller must be disposed of in accordance with current regulations.

Some of the components used in the devices can cause damage to the environment if incorrectly disposed.



## 7. TECHNICAL SPECIFICATIONS

INPUTS		
<b>INA1, INA2, INA3 - Analogue control inputs</b>		
Power control % value acquisition function	Configurable	Yes, via software
	Voltage	Linear: 0...5 Vdc, Ri = 90 kΩ Linear: 0...10 Vdc, Ri = 90 kΩ
	Current	Linear: 0/4...20 mA, Ri = 250 Ω
	Potentiometer	1...10 kΩ, 5 Vdc power supply max 30 mA from Thyritop 600
RMS line voltage measurement function	Line frequency	50-60 Hz
	Voltage range	90...530 Vac for models with 480 Vac working voltage 90...660 Vac for models with 600 Vac working voltage 90...760 Vac for models with 690 Vac working voltage
	Accuracy	1% f.s. with neutral connected 2% f.s. without neutral
RMS current measurement function	Current reading	In the load
	Accuracy	In ZC and BF start mode: 2% f.s. @25 °C In PA mode; 2% f.s. with conduction angle > 90° 4% f.s. with conduction angle < 90°
RMS load voltage measurement function	Voltage reading	On the load
	Accuracy	1% f.s. with VLOAD measurement option (in the absence of the option, the value is calculated from the line voltage and power output values, accuracy 2% f.s.)
Inputs measuring current from external CTs	Number	3 (optional)
	Input impedance	16 mΩ
	Input dynamic	0...5 Arms
	Accuracy	1% f.s.
Thermal drift for measuring voltage and current in the load, line voltage		< 0.02 %/°C
Current and voltage sampling time		0.25 ms
<b>INDIG1...INDIG4 - Digital inputs</b>		
Function	Configurable	Yes (default disabled)
	PWM input for cycle-dependent % power control	Only for INDIG1, INDIG2 and INDIG3: the function allows a power set point to be set by means of a digital signal (e.g., from a PLC or controller with a PWM output). Available frequency range: INDIG1: 100 Hz / 0.03 Hz INDIG2 and INDIG3: 1 Hz / 0.03 Hz
Input	Type	PNP or NPN configurable via software
	Voltage	5...30 Vdc
	Current	7 mA
	Insulation	1500 V

## OUTPUTS

<b>OUT1, OUT2, OUT3 - Heating outputs</b> (connected directly to static units)		
Function	Configurable	Yes (default hot setting)
	Status display	Via LED (O1, O2, O3)
	Connection	OUT1: Thyritop 600 OUT2: Thyritop 600-E1 OUT3: Thyritop 600-E2
<b>OUT5...OUT8 - Auxiliary outputs (option)</b>		
Function	Configurable	Yes
Relay outputs (R)	Number	4
	Type	NO contact with single common
	Max. voltage	250 V / 30 Vdc $\cos\phi = 1$
	Max. current single relay	3 A
	Total max. current	12 A
Analogue outputs (W)	Number	3 configurable via software
	Type	0...10 V, max 25 mA
		2...10 V, max 25 mA
		0...20 mA, maximum load 500 $\Omega$ 4...20 mA (default), maximum load 500 $\Omega$
	Insulation	500 V
	Resolution	12 bit
Accuracy	0.2% f.s.	
Digital outputs (D)	Number	4
	Type	High-side current emission
	Voltage	0 V...(18...36 Vdc depending on product power supply value)
	Max. current	20 mA
<b>OUT9, OUT10 - Alarms</b>		
Function	Configurable	Yes (default alarms)
Relay outputs	Number	2
	Type	Changeover contact (C, NO, NC)
	Max. voltage	250 V / 30 Vdc $\cos\phi = 1$
	Max. current single relay	5 A

## COMMUNICATION PORTS

<b>PORT Thyritop 600 Remote</b>		
Function		Serial communication for Thyritop 600 Remote terminal for parameter display/programming
<b>DOOR 1 (always present)</b>		
Function		Modbus serial communication
Port	Number	2
	Type	RS-485
	Insulation	1500 V
	Connector	RJ10 4-4 telephone type
	Line termination	DIP switch
Communication	Node address	Adjustable via rotary-switches
	Protocol	Modbus RTU
	Baudrate	1200...115 200 kbit/s (default 19.2 kbit/s)
<b>PORT2 (Fieldbus option)</b>		
Function		Fieldbus serial communications
Hardware configuration	Type M	2 Modbus RTU ports
	Type P	1 Modbus RTU port 1 Profibus DP port
	Type C	1 Modbus RTU port 1 CANopen port
	Type E	1 Modbus RTU port 1 Ethernet Modbus TCP port
	Type E6	1 Modbus RTU port 1 Profinet port
	Type E7	1 Modbus RTU port 1 EtherCAT port
	Type E8	1 Modbus RTU port 1 IP Ethernet port
	Modbus RTU port	Type
Insulation		1500 V
Connector		RJ10 4-4 telephone type
Line termination		DIP switch
Profibus DP port	Type	Profibus DP
	Connector	D-SUB 9-pole male
	Line termination	To be made with resistors
CANopen port	Type	CAN
	Connector	D-SUB 9-pole female
	Line termination	To be made with resistors
Ethernet Modbus TCP port	Type	Ethernet
	Connector	RJ45
ProfiNET port	Type	Ethernet
	Connector	RJ45
EtherCAT port	Type	Ethernet
	Connector	RJ45
Ethernet/IP port	Type	Ethernet
	Connector	RJ45
Baudrate	Modbus RTU	1200...115 000 kbit/s
	CANopen	10 kbit/s...1 Mbit/s
	Profibus DP	9.6 kbit/s...12 Mbit/s
	Modbus TCP Ethernet	10/100 Mbit/s
	Ethernet IP	10/100 Mbit/s
	EtherCAT	100 Mbit/s ...

## POWER (Static Group)

CATEGORY OF USE (EN60947-4-3 Tab. 2)		AC 51 resistive or low-inductance loads AC 55b short-wave infrared lamps (SWIR) AC 56a transformers, high temperature coefficient resistive loads
Functions	Trigger modes	<p><b>PA:</b> load management by adjusting the power-on phase angle.</p> <p><b>ZC:</b> Zero Crossing with constant cycle time (settable in the range 1...200 sec).</p> <p><b>BF:</b> Burst Firing with min. optimised variable cycle time (GTT).</p> <p><b>HSC:</b> Half Single Cycle, corresponds to a Burst Firing which handles half on/off cycles. Useful for reducing flickering with short-wave infrared loads (applies only to single-phase resistive or three-phase open delta 6-wire loads).</p>
	Feedback mode <i>(recalibration is required each time the feedback mode is changed)</i>	<p><b>V, V<sup>2</sup>:</b> Voltage feedback, proportional to the RMS value of the voltage on the load to compensate for possible variations in line voltage.</p> <p><b>I, I<sup>2</sup>:</b> Current feedback, proportional to the RMS value of the current in the load to compensate for possible variations in line voltage and/or variations in load impedance.</p> <p><b>P:</b> Power feedback, proportional to the actual power value on the load to compensate for line voltage variations and/or load impedance variations.</p>
General electrical specifications	Max. rated voltage	480 Vac or 600 Vac or 690 Vac, depending on the model
	Working voltage range	480 Vac models: 90...530 Vac 600 Vac models: 90...660 Vac 690 Vac models: 90...760 Vac
	Non-repetitive voltage	480 Vac models: 1200 Vp 600 Vac and 690 Vac models: 1600 Vp
	Rated frequency	50/60 Hz with auto-determination
	Critical Dv/dt with output disabled	1000 V/μsec
	Rated impulse withstand voltage	4 kV
	Rated current in short circuit condition	5 kA
	Protections	RC, ultra-rapid fuses for SCR only

Nominal current AC 51 <i>(non-inductive or slightly inductive loads, resistance furnaces)</i>	Thyritop 600 40	Rated current: 40 Arms @ 40 °C in continuous service Non-repetitive overcurrent, t = 10 ms: 1400 A I <sup>2</sup> t for blowout: 10 000 A <sup>2</sup> s
	Thyritop 600 60	Rated current: 60 Arms @ 40 °C in continuous service Non-repetitive overcurrent, t = 10 ms: 1500 A I <sup>2</sup> t for blowout: 12 000 A <sup>2</sup> s
	Thyritop 600 100	Rated current: 100 Arms @ 40 °C in continuous service Non-repetitive overcurrent, t=10 ms: 1900 A I <sup>2</sup> t for blowout: 18 000 A <sup>2</sup> s
	Thyritop 600 150	Rated current: 150 Arms @ 40 °C in continuous service Non-repetitive overcurrent, t = 10 ms: 5000 A I <sup>2</sup> t for blowout: 125 000 A <sup>2</sup> s
	Thyritop 600 200	Rated current: 200 Arms @ 40 °C in continuous service Non-repetitive overcurrent, t = 10 ms: 8000 A I <sup>2</sup> t for blowout: 320 000 A <sup>2</sup> s
	Thyritop 600 250	Rated current: 250 Arms @ 40 °C in continuous service Non-repetitive overcurrent, t = 10 ms: 8000 A I <sup>2</sup> t for blowout: 320 000 A <sup>2</sup> s
	Thyritop 600 300	Rated current: 300 Arms @ 40 °C in continuous service. Non-repetitive overcurrent, t = 10 ms: 8000 A I <sup>2</sup> t for blowout: 320 000 A <sup>2</sup> s
	Thyritop 600 400	Rated current: 400 Arms @ 50 °C in continuous service Non-repetitive overcurrent, t = 10 ms: 8000 A I <sup>2</sup> t for blowout: 320 000 A <sup>2</sup> s
	Thyritop 600 500	Rated current: 500 Arms @ 50 °C in continuous service. Non-repetitive overcurrent, t = 10 ms: 15 000 A I <sup>2</sup> t for blowout: 1 125 000 A <sup>2</sup> s Critical dV/dt: 1000V/μs
	Thyritop 600 600	Rated current: 600 Arms @ 50 °C in continuous service Non-repetitive overcurrent, t = 10 ms: 15 000 A I <sup>2</sup> t for blowout: 1 125 000 A <sup>2</sup> s
	Minimum controllable load (all models)	5% of the nominal current rating of the product
Heat dissipation		The thermal power dissipated is a function of the load current: $P_{\text{dissipation}} = 1.3 \text{ W} \times I_{\text{load}}$ For models with a built-in fuse, also consider the power dissipation of the fuse at the rated current.
Rated current AC 56A	Permitted triggering modes	ZC, BF with DT (Delay Triggering), PA with softstart
	Derating	20% of the nominal current value

## FUNCTIONS

Diagnostics	General	<ul style="list-style-type: none"> <li>• Timed softstart ramp, with or without peak current control.</li> <li>• Softstart ramp, specifically for infrared lamps.</li> <li>• Time-controlled switch-off ramp.</li> <li>• RMS load current limitation.</li> <li>• Delay-Triggering 0-90° for firing inductive loads in ZC and BF mode.</li> <li>• SCR short circuit (current presence with OFF command).</li> <li>• No line voltage.</li> <li>• No fan power supply.</li> <li>• No current due to open SCR/disconnected load.</li> <li>• Over-temperature alarm (from the power module, power cable terminals or fuse).</li> </ul>
	Current reading	<ul style="list-style-type: none"> <li>• HB alarm from an interrupted or partially interrupted load.</li> <li>• Automatic calibration of the HB alarm threshold based on the current level in the load.</li> <li>• Load short circuit or overcurrent alarm</li> </ul>
	Voltage reading	<ul style="list-style-type: none"> <li>• Three-phase line unbalanced.</li> <li>• Incorrect phase rotation in three-phase load configuration.</li> </ul>
Energy calculation		Total energy value supplied to load with local display via terminal and remote acquisition via fieldbus
	Visualisation	Local via terminal or remote acquisition via fieldbus.
	Counter reset	Yes
Type of connection and controllable load (selection via DIP switch)	with Thyritop 600-M only	1 single-phase load
	with Thyritop 600 2PH	2 single-phase loads, or only in ZC and BF trigger modes: 1 three-phase closed delta load controlled on two phases, or 1 three-phase star load without neutral controlled on two phases
	with Thyritop 600 3 PH	3 single-phase loads, or 3 independent single-phase open delta loads, or 1 three-phase open delta load, or 1 three-phase closed delta load, or 1 three-phase star load with neutral, or 1 three-phase star load without neutral

## GENERAL DATA

Power supply	Thyritop 600 1PH/2PH/3PH (models from 40 to 300 A)	Voltage: 24 VDC $\pm$ 10% Power consumption: 25 max
	Thyritop 600 1PH- 400/500/600A	Voltage: 24 VDC $\pm$ 10% Power consumption: 38 max
	Thyritop 600 2PH- 400/500/600A	Voltage: 24 VDC $\pm$ 10% Power consumption: 66 max
	Thyritop 600 3PH- 400/500/600A	Voltage: 24 VDC $\pm$ 10% Power consumption: 94 max
LED indicators	Number	8
	Function	RN (green): CPU operating status ER (red): error signal DI1, DI2 (yellow): status of digital inputs INDIG1 and INDIG2 O1, O2, O3 (yellow): power control status BT (yellow): HB button status
Environmental conditions	Use	Indoors, altitude up to 2,000 m
	Altitude	2,000 m max
	Operating temperature	0...50 °C (see dissipation curves)
	Storage temperature	-20...+85 °C
	Relative humidity	20...85% non-condensing RH
Protection rating		IP20
Assembly	Positioning	On panel, screw fixing
	Installation requirements	Installation category: II Pollution rating: 2 Insulation: double Maximum air temperature around the device: 50 °C (see derating curves for temperatures > 50 °C) Device type: "UL Open Type"
Dimensions		See dimensional drawings
Weight	Thyritop 600 40 A, Thyritop 600 60 A, Thyritop 600 100 A	Thyritop 600-1PH: 3.2 kg Thyritop 600-2PH: 5.2 kg Thyritop 600-3PH: 7.2 kg
	Thyritop 600 150 A	Thyritop 600-1PH: 3.3 kg Thyritop 600-2PH: 5.4 kg Thyritop 600-3PH: 7.5 kg
	Thyritop 600 200 A, Thyritop 600 250 A, Thyritop 600 300 A	Thyritop 600-1PH: 3.6 kg Thyritop 600-2PH: 6.0 kg Thyritop 600-3PH: 8.4 kg
	Thyritop 600 400 A	Thyritop 600-1PH: 8.0 kg Thyritop 600-2PH: 15.5 kg Thyritop 600-3PH: 22.5 kg
	Thyritop 600 500 A, Thyritop 600 600 A	Thyritop 600-1PH: 11.0 kg Thyritop 600-2PH: 21.0 kg Thyritop 600-3PH: 31.0 kg



## 7.1. Derating curves

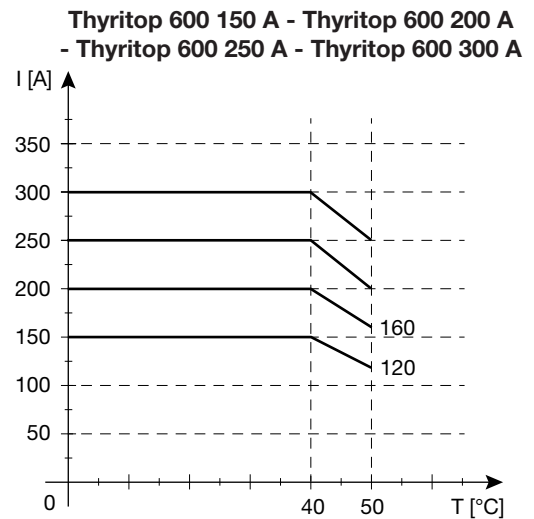
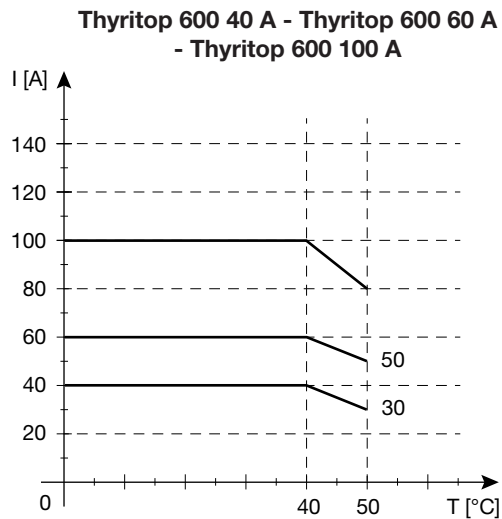

**Thyritop 600 400 A - Thyritop 600 500 A - Thyritop 600 600 A**

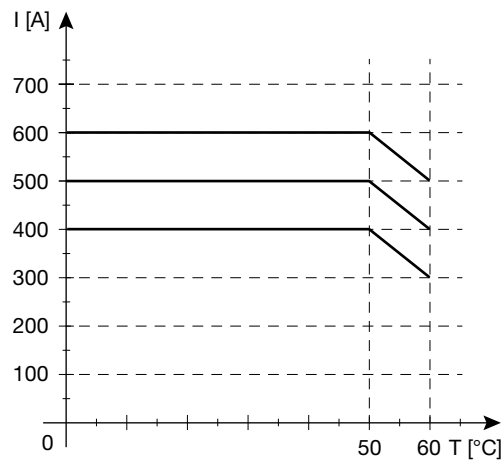

## 8. ORDER CODES

Order code: TH600 [ ] - [ ] - [ ] -0-0-[ ] - [ ] - [ ] - 1 - [ ]

Model	
Single-phase model (Thyritop 600)	<b>1PH</b>
Two-phase model (Thyritop 600 + Thyritop 600-E1)	<b>2PH</b>
Three-phase module (Thyritop 600 + Thyritop 600-E1/2)	<b>3PH</b>

Rated current:	
40 A	<b>40</b>
60 A	<b>60</b>
100 A	<b>100</b>
150 A	<b>150</b>
200 A	<b>200</b>
250 A	<b>250</b>
300 A	<b>300</b>
400 A	<b>400</b>
500 A	<b>500</b>
600 A	<b>600</b>

Rated voltage	
480 Vac *	<b>480</b>
690 Vac	<b>690</b>

Control options	
Absent	<b>0</b>
Current limits	<b>1</b>
Current limit and feedback V, I, P	<b>2</b>
Current limit and feedback V, I, P + "Vload" input	<b>3</b>
Current limit and feedback V, I, P + "Vload" input + 3 inputs from external CTs **	<b>4</b>

Fieldbus Port 2	
Absent	<b>0</b>
Modbus RTU	<b>M</b>
Profibus DP	<b>P</b>
CANopen	<b>C</b>
Modbus TCP Ethernet	<b>E</b>
Profinet	<b>E6</b>
EtherCAT	<b>E7</b>
Ethernet IP	<b>E8</b>

Diagnostics and alarm options	
Absent	<b>0</b>
Partial and total load break alarm (HB) + Diagnostic alarms	<b>1</b>

Optional auxiliary outputs	
Absent	<b>0</b>
4 relays	<b>R</b>
4 digital outputs	<b>W</b>
3 analogue retransmission outputs 12 bit, 0-10 V, 4-20 mA	<b>W</b>

**Note**

- \*) Option NOT available for models with rated current  $\geq 400$  A
- \*\*) Option NOT available for 690 Vac models with rated current  $\leq 300$  A

## 9. ACCESSORIES

### 9.1. Software and interface



Configuration / supervision software for the THYRITOP 600 using a PC/PLC equipped with a USB port (Windows environment).

Allows to read or write all the parameters of a THYRITOP 600 controller  
One software for all models.

- Quick and easy product configuration.
- Copy/paste functions, recipe saving, trends.
- Online trends and historical data storage.

**Free software downloadable from [www.pyrocontrole.com](http://www.pyrocontrole.com)**

Option: USB cable for connecting THYRITOP 600 and PC .....Code. P01660101



The man/machine interface is simple, immediate and highly functional, thanks to the THYRITOP REMOTE programming box (optional).

Option: USB cable for connecting THYRITOP 600 and PC

Allows to read all the control parameters of the THYRITOP 600.

It is connected via a 9-pole D-SUB connector and is installed on the front of the THYRITOP 600-M, using a magnetic plate.

- Alphanumeric display with 5 lines and 21 characters.
- Keys for displaying variables and programming parameters.
- Magnetic fastening

**ORDERING CODE**

THYRITOP REMOTE.....Code. PO1666600

## 9.2. Ultrarapid fuses

Model	ULTRARAPID FUSES			
	Size I <sup>2</sup> t	Code Format	Model Code	Power dissipated @ In
THYRITOP 600 40 A	80A 2500A <sup>2</sup> s	FUS-080S	P01660035	5 W
THYRITOP 600 60 A	125A 8900A <sup>2</sup> s	FUS-125S	P01660036	6 W
THYRITOP 600 100 A	160A 16000A <sup>2</sup> s	FUS-160S	P01660037	12 W
THYRITOP 600 150 A	200A 31500A <sup>2</sup> s	FUS-200S	P01660033	19 W
THYRITOP 600 200/250/300 A 480/600 V	450A 196000A <sup>2</sup> s	FUS-450S	P01660034	17 W
THYRITOP 600 400 A	«630A 310000A <sup>2</sup> s»	FUS-630S	P01660038	60 W
THYRITOP 600 500/600A	«1000A 970000A <sup>2</sup> s»	FUS-1000	P01660039	50 W

### 9.3. Short-circuit protection / SCCR

The products listed in the table are suitable for use in circuits capable of supplying up to 100 000 RMS symmetrical amps, 600 V max if protected by fuses.

Use fuses only.

The tests at 100 000 A were carried out with class J fuses with range xxxA (refer to the table to determine the fuse size) in accordance with standard UL508.

After a short circuit the operation of the device is not guaranteed. In order to ensure the operation of the device after a short circuit, the use of ultrafast fuses is recommended.



**Caution!** The opening of the circuit protection device may indicate that it has been tripped by a fault.

To reduce the risk of fire or electric shock, current-carrying parts and other components of the device should be examined and replaced if damaged. If the device is completely damaged, it must be replaced.

SCCR RM SYM 100KA 600V		UL508 SCCR FUSE TABLE			
Model	Configuration	Short circuit current [RMS Amps]	Max fuse size [A]	Fuse Class	Max Voltage [Vac]
Thyritop 600 100	1PH, 2PH, 3PH	100,000	100	J	600
Thyritop 600 200	1PH, 2PH, 3PH	100,000	400	J	600
Thyritop 600 250	1PH, 2PH, 3PH	100,000	400	J	600
Thyritop 600 300	1PH, 2PH, 3PH	100,000	400	J	600
Thyritop 600 400	1PH, 2PH, 3PH	100,000	400	J	600
Thyritop 600 500	1PH, 2PH, 3PH	100,000	600	J	600
Thyritop 600 600	1PH, 2PH, 3PH	100,000	600	J	600

The fuses listed above are representative of all fuses of the same class with lower current ratings.

906121687\_NF\_THYRITOP 600\_08-2021\_GB

<b>UL</b>	Conformity C/UL/US File no. E522688- NRNT, NRNT7, NRNT2, NRNT8
<b>CE</b>	Electromagnetic Compatibility EMC: Compliance with Directive 2014/30/EU with reference to EN 31326-1 Industrial emission class A - LVD safety: Compliance with Directive 2014/35/EU with reference to EN61010-1

**FRANCE**

**Pyrocontrole**

6 bis, av. du Docteur Schweitzer  
69881 MEYZIEU Cedex  
Tél : +33 4 72 14 15 40  
Fax : +33 4 72 14 15 41  
info@pyrocontrole.com  
www.pyrocontrole.com

**INTERNATIONAL**

**Pyrocontrole**

Tél : +33 4 72 14 15 55  
Fax : +33 4 72 14 15 41



**Our international contacts**

<http://www.pyrocontrole.com/fr/contact-us/international>